

## 1K/2K/4K 2.0V Microwire® Serial EEPROM

### FEATURES

- Single supply with programming operation down to 2.0V (Commercial only)
- Low power CMOS technology
  - 1 mA active current typical
  - 5  $\mu$ A standby current (typical) at 3.0V
- ORG pin selectable memory configuration
  - 128 x 8- or 64 x 16-bit organization (93LC46)
  - 256 x 8- or 128 x 16-bit organization (93LC56)
  - 512 x 8- or 256 x 16-bit organization (93LC66)
- Self-timed ERASE and WRITE cycles (including auto-erase)
- Automatic ERAL before WRAL
- Power on/off data protection circuitry
- Industry standard 3-wire serial I/O
- Device status signal during ERASE/WRITE cycles
- Sequential READ function
- 10,000,000 ERASE/WRITE cycles guaranteed on 93LC56 and 93LC66
- 1,000,000 E/W cycles guaranteed on 93LC46
- Data retention > 200 years
- 8-pin PDIP/SOIC and 14-pin SOIC package (SOIC in JEDEC and EIAJ standards)
- Temperature ranges supported
  - Commercial (C): 0°C to +70°C
  - Industrial (I): -40°C to +85°C

### BLOCK DIAGRAM

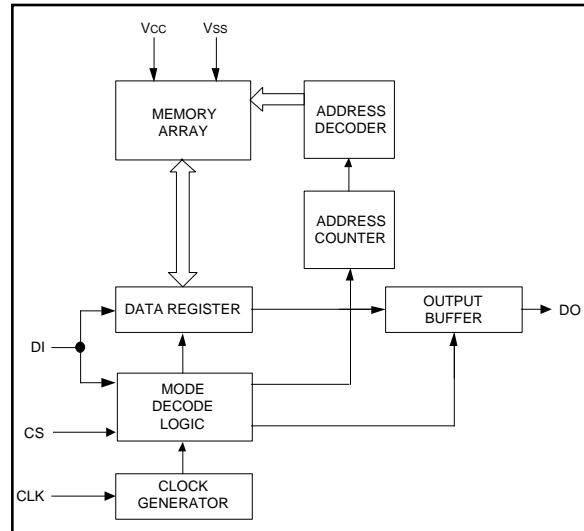

### DESCRIPTION

The Microchip Technology Inc. 93LC46/56/66 are 1K, 2K and 4K low voltage serial Electrically Erasable PROMs. The device memory is configured as x8 or x16 bits depending on the ORG pin setup. Advanced CMOS technology makes these devices ideal for low power non-volatile memory applications. The 93LC Series is available in standard 8-pin DIP and 8/14-pin surface mount SOIC packages. The 93LC46X/56X/66X are offered in "SN" package only.

### PACKAGE TYPES

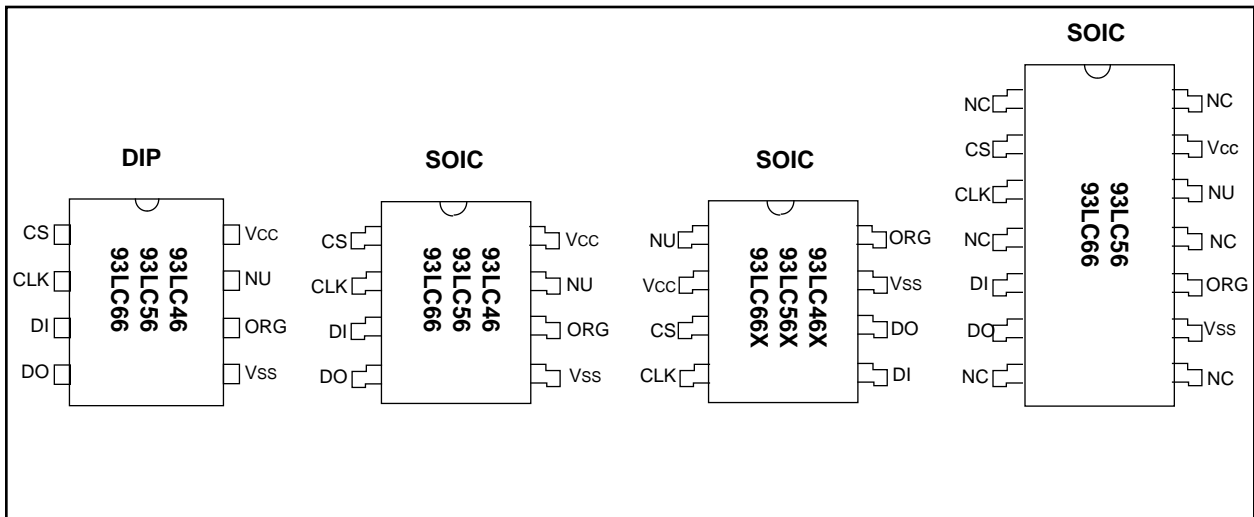

Microwire is a registered trademark of National Semiconductor Incorporated.

# 93LC46/56/66

## 1.0 ELECTRICAL CHARACTERISTICS

### 1.1 Maximum Ratings\*

V<sub>CC</sub> ..... 7.0V  
 All inputs and outputs w.r.t. V<sub>SS</sub> ..... -0.6V to V<sub>CC</sub> +1.0V  
 Storage temperature ..... -65°C to +150°C  
 Ambient temp. with power applied..... -65°C to +125°C  
 Soldering temperature of leads (10 seconds) ..... +300°C  
 ESD protection on all pins ..... 4 kV

\***Notice:** Stresses above those listed under "Maximum ratings" may cause permanent damage to the device. This is a stress rating only and functional operation of the device at those or any other conditions above those indicated in the operational listings of this specification is not implied. Exposure to maximum rating conditions for extended periods may affect device reliability.

TABLE 1-1: PIN FUNCTION TABLE

Name	Function
CS	Chip Select
CLK	Serial Data Clock
DI	Serial Data Input
DO	Serial Data Output
V <sub>SS</sub>	Ground
ORG	Memory Configuration
NU	Not Utilized
NC	No Connect
V <sub>CC</sub>	Power Supply

TABLE 1-2: DC AND AC ELECTRICAL CHARACTERISTICS

Parameter	Symbol	Min.	Max.	Units	Conditions
High level input voltage	V <sub>IH1</sub>	2.0	V <sub>CC</sub> +1	V	V <sub>CC</sub> ≥ 2.7V
	V <sub>IH2</sub>	0.7 V <sub>CC</sub>	V <sub>CC</sub> +1	V	V <sub>CC</sub> < 2.7V
Low level input voltage	V <sub>IL1</sub>	-0.3	0.8	V	V <sub>CC</sub> ≥ 2.7V
	V <sub>IL2</sub>	-0.3	0.2 V <sub>CC</sub>	V	V <sub>CC</sub> < 2.7V
Low level output voltage	V <sub>OL1</sub>	—	0.4	V	I <sub>OL</sub> = 2.1 mA; V <sub>CC</sub> = 4.5V
	V <sub>OL2</sub>	—	0.2	V	I <sub>OL</sub> = 100 μA; V <sub>CC</sub> = V <sub>CC</sub> Min.
High level output voltage	V <sub>OH1</sub>	2.4	—	V	I <sub>OH</sub> = -400 μA; V <sub>CC</sub> = 4.5V
	V <sub>OH2</sub>	V <sub>CC</sub> -0.2	—	V	I <sub>OH</sub> = -100 μA; V <sub>CC</sub> = V <sub>CC</sub> Min.
Input leakage current	I <sub>LI</sub>	-10	10	μA	V <sub>IN</sub> = 0.1V to V <sub>CC</sub>
Output leakage current	I <sub>LO</sub>	-10	10	μA	V <sub>OUT</sub> = 0.1V to V <sub>CC</sub>
Pin capacitance (all inputs/outputs)	C <sub>IN</sub> , C <sub>OUT</sub>	—	7	pF	V <sub>IN</sub> /V <sub>OUT</sub> = 0 V (Note 1 & 3) Tamb = +25°C, F <sub>CLK</sub> = 1 MHz
Operating current	I <sub>CC</sub> write	—	3	mA	F <sub>CLK</sub> = 2 MHz; V <sub>CC</sub> = 6.0V (Note 3)
	I <sub>CC</sub> read	—	1	mA	F <sub>CLK</sub> = 2 MHz; V <sub>CC</sub> = 6.0V
Standby current	I <sub>CCS</sub>	—	500	μA	F <sub>CLK</sub> = 1 MHz; V <sub>CC</sub> = 3.0V
			100	μA	CLK = CS = 0V; V <sub>CC</sub> = 6.0V
Clock frequency	F <sub>CLK</sub>	—	30	μA	CLK = CS = 0V; V <sub>CC</sub> = 3.0V
			2	MHz	V <sub>CC</sub> ≥ 4.5V
Clock high time	T <sub>CKH</sub>	250	1	MHz	V <sub>CC</sub> < 4.5V
			—	ns	
Clock low time	T <sub>CKL</sub>	250	—	ns	
Chip select setup time	T <sub>CSS</sub>	50	—	ns	Relative to CLK
Chip select hold time	T <sub>CSh</sub>	0	—	ns	Relative to CLK
Chip select low time	T <sub>CSL</sub>	250	—	ns	
Data input setup time	T <sub>DIS</sub>	100	—	ns	Relative to CLK
Data input hold time	T <sub>DIH</sub>	100	—	ns	Relative to CLK
Data output delay time	T <sub>PD</sub>	—	400	ns	CL = 100 pF
Data output disable time	T <sub>CZ</sub>	—	100	ns	CL = 100 pF (Note 3)
Status valid time	T <sub>SV</sub>	—	500	ns	CL = 100 pF
Program cycle time	T <sub>WC</sub>	—	10	ms	ERASE/WRITE mode (Note 2)
	T <sub>EC</sub>	—	15	ms	ERAL mode
	T <sub>WL</sub>	—	30	ms	WRAL mode
Endurance		—	1M	—	cycles
		—	10M	—	

Note 1: This parameter is tested at Tamb = 25°C and F<sub>CLK</sub> = 1 MHz.

2: Typical program cycle time is 4 ms per word.

3: This parameter is periodically sampled and not 100% tested.

4: This application is not tested but guaranteed by characterization. For endurance estimates in a specific application, please consult the Total Endurance Model which can be obtained on our BBS or website.

**TABLE 1-3: INSTRUCTION SET FOR 93LC46: ORG = 1 (X 16 ORGANIZATION)**

Instruction	SB	Opcode	Address	Data In	Data Out	Req. CLK Cycles
READ	1	10	A5 A4 A3 A2 A1 A0	—	D15 - D0	25
EWEN	1	00	1 1 X X X X	—	High-Z	9
ERASE	1	11	A5 A4 A3 A2 A1 A0	—	(RDY/BSY)	9
ERAL	1	00	1 0 X X X X	—	(RDY/BSY)	9
WRITE	1	01	A5 A4 A3 A2 A1 A0	D15 - D0	(RDY/BSY)	25
WRAL	1	00	0 1 X X X X	D15 - D0	(RDY/BSY)	25
EWDS	1	00	0 0 X X X X	—	High-Z	9

**TABLE 1-4: INSTRUCTION SET FOR 93LC46: ORG = 0 (X 8 ORGANIZATION)**

Instruction	SB	Opcode	Address	Data In	Data Out	Req. CLK Cycles
READ	1	10	A6 A5 A4 A3 A2 A1 A0	—	D7 - D0	18
EWEN	1	00	1 1 X X X X	—	High-Z	10
ERASE	1	11	A6 A5 A4 A3 A2 A1 A0	—	(RDY/BSY)	10
ERAL	1	00	1 0 X X X X	—	(RDY/BSY)	10
WRITE	1	01	A6 A5 A4 A3 A2 A1 A0	D7 - D0	(RDY/BSY)	18
WRAL	1	00	0 1 X X X X	D7 - D0	(RDY/BSY)	18
EWDS	1	00	0 0 X X X X	—	High-Z	10

**TABLE 1-5: INSTRUCTION SET FOR 93LC56: ORG = 1 (X 16 ORGANIZATION)**

Instruction	SB	Opcode	Address	Data In	Data Out	Req. CLK Cycles
READ	1	10	X A6 A5 A4 A3 A2 A1 A0	—	D15 - D0	27
EWEN	1	00	1 1 X X X X X X	—	High-Z	11
ERASE	1	11	X A6 A5 A4 A3 A2 A1 A0	—	(RDY/BSY)	11
ERAL	1	00	1 0 X X X X X X	—	(RDY/BSY)	11
WRITE	1	01	X A6 A5 A4 A3 A2 A1 A0	D15 - D0	(RDY/BSY)	27
WRAL	1	00	0 1 X X X X X X	D15 - D0	(RDY/BSY)	27
EWDS	1	00	0 0 X X X X X X	—	High-Z	11

**TABLE 1-6: INSTRUCTION SET FOR 93LC56: ORG = 0 (X 8 ORGANIZATION)**

Instruction	SB	Opcode	Address	Data In	Data Out	Req. CLK Cycles
READ	1	10	X A7 A6 A5 A4 A3 A2 A1 A0	—	D7 - D0	20
EWEN	1	00	1 1 X X X X X X	—	High-Z	12
ERASE	1	11	X A7 A6 A5 A4 A3 A2 A1 A0	—	(RDY/BSY)	12
ERAL	1	00	1 0 X X X X X X	—	(RDY/BSY)	12
WRITE	1	01	X A7 A6 A5 A4 A3 A2 A1 A0	D7 - D0	(RDY/BSY)	20
WRAL	1	00	0 1 X X X X X X	D7 - D0	(RDY/BSY)	20
EWDS	1	00	0 0 X X X X X X	—	High-Z	12

**TABLE 1-7: INSTRUCTION SET FOR 93LC66: ORG = 1 (X 16 ORGANIZATION)**

Instruction	SB	Opcode	Address	Data In	Data Out	Req. CLK Cycles
READ	1	10	A7 A6 A5 A4 A3 A2 A1 A0	—	D15 - D0	27
EWEN	1	00	1 1 X X X X X X	—	High-Z	11
ERASE	1	11	A7 A6 A5 A4 A3 A2 A1 A0	—	(RDY/BSY)	11
ERAL	1	00	1 0 X X X X X X	—	(RDY/BSY)	11
WRITE	1	01	A7 A6 A5 A4 A3 A2 A1 A0	D15 - D0	(RDY/BSY)	27
WRAL	1	00	0 1 X X X X X X	D15 - D0	(RDY/BSY)	27
EWDS	1	00	0 0 X X X X X X	—	High-Z	11

**TABLE 1-8: INSTRUCTION SET FOR 93LC66: ORG = 0 (X 8 ORGANIZATION)**

Instruction	SB	Opcode	Address	Data In	Data Out	Req. CLK Cycles
READ	1	10	A8 A7 A6 A5 A4 A3 A2 A1 A0	—	D7 - D0	20
EWEN	1	00	1 1 X X X X X X	—	High-Z	12
ERASE	1	11	A8 A7 A6 A5 A4 A3 A2 A1 A0	—	(RDY/BSY)	12
ERAL	1	00	1 0 X X X X X X	—	(RDY/BSY)	12
WRITE	1	01	A8 A7 A6 A5 A4 A3 A2 A1 A0	D7 - D0	(RDY/BSY)	20
WRAL	1	00	0 1 X X X X X X	D7 - D0	(RDY/BSY)	20
EWDS	1	00	0 0 X X X X X X	—	High-Z	12

## 2.0 FUNCTIONAL DESCRIPTION

When the ORG pin is connected to Vcc, the (x16) organization is selected. When it is connected to ground, the (x8) organization is selected. Instructions, addresses and write data are clocked into the DI pin on the rising edge of the clock (CLK). The DO pin is normally held in a high-Z state except when reading data from the device, or when checking the READY/ $\overline{\text{BUSY}}$  status during a programming operation. The READY/ $\overline{\text{BUSY}}$  status can be verified during an Erase/Write operation by polling the DO pin; DO low indicates that programming is still in progress, while DO high indicates the device is ready. The DO will enter the high-Z state on the falling edge of the CS.

### 2.1 START Condition

The START bit is detected by the device if CS and DI are both HIGH with respect to the positive edge of CLK for the first time.

Before a START condition is detected, CS, CLK, and DI may change in any combination (except to that of a START condition), without resulting in any device operation (READ, WRITE, ERASE, EWEN, EWDS, ERAL, and WRAL). As soon as CS is HIGH, the device is no longer in the standby mode.

An instruction following a START condition will only be executed if the required amount of opcode, address and data bits for any particular instruction is clocked in.

After execution of an instruction (i.e., clock in or out of the last required address or data bit) CLK and DI become don't care bits until a new start condition is detected.

### 2.2 DI/DO

It is possible to connect the Data In and Data Out pins together. However, with this configuration it is possible for a "bus conflict" to occur during the "dummy zero" that precedes the READ operation, if A0 is a logic HIGH level. Under such a condition the voltage level seen at Data Out is undefined and will depend upon the relative impedances of Data Out and the signal source driving A0. The higher the current sourcing capability of A0, the higher the voltage at the Data Out pin.

### 2.3 Data Protection

During power-up, all programming modes of operation are inhibited until Vcc has reached a level greater than 1.4V. During power-down, the source data protection circuitry acts to inhibit all programming modes when Vcc has fallen below 1.4V at nominal conditions.

The EWEN and EWDS commands give additional protection against accidentally programming during normal operation.

After power-up, the device is automatically in the EWDS mode. Therefore, an EWEN instruction must be performed before any ERASE or WRITE instruction can be executed.

## 2.4 READ

The READ instruction outputs the serial data of the addressed memory location on the DO pin. A dummy zero bit precedes the 16 bit (x16 organization) or 8 bit (x8 organization) output string. The output data bits will toggle on the rising edge of the CLK and are stable after the specified time delay (TPD). Sequential read is possible when CS is held high. The memory data will automatically cycle to the next register and output sequentially.

### 2.5 Erase/Write Disable and Enable (EWEN, EWDS)

The 93LC46/56/66 powers up in the Erase/Write Disable (EWDS) state. All programming modes must be preceded by an Erase/Write Enable (EWEN) instruction. Once the EWEN instruction is executed, programming remains enabled until an EWDS instruction is executed or Vcc is removed from the device. To protect against accidental data disturb, the EWDS instruction can be used to disable all Erase/Write functions and should follow all programming operations. Execution of a READ instruction is independent of both the EWEN and EWDS instructions.

### 2.6 ERASE

The ERASE instruction forces all data bits of the specified address to the logical "1" state. CS is brought low following the loading of the last address bit. This falling edge of the CS pin initiates the self-timed programming cycle.

The DO pin indicates the READY/ $\overline{\text{BUSY}}$  status of the device if CS is brought high after a minimum of 250 ns low (TCSL). DO at logical "0" indicates that programming is still in progress. DO at logical "1" indicates that the register at the specified address has been erased and the device is ready for another instruction.

The ERASE cycle takes 4 ms per word (Typical).

### 2.7 WRITE

The WRITE instruction is followed by 16 bits (or by 8 bits) of data which are written into the specified address. After the last data bit is put on the DI pin, CS must be brought low before the next rising edge of the CLK clock. This falling edge of CS initiates the self-timed auto-erase and programming cycle.

The DO pin indicates the READY/ $\overline{\text{BUSY}}$  status of the device if CS is brought high after a minimum of 250 ns low (TCSL) and before the entire write cycle is complete. DO at logical "0" indicates that programming is still in progress. DO at logical "1" indicates that the register at the specified address has been written with the data specified and the device is ready for another instruction.

The WRITE cycle takes 4 ms per word (Typical).

## 2.8 Erase All (ERAL)

The ERAL instruction will erase the entire memory array to the logical "1" state. The ERAL cycle is identical to the ERASE cycle except for the different opcode. The ERAL cycle is completely self-timed and commences at the falling edge of the CS. Clocking of the CLK pin is not necessary after the device has entered the self clocking mode. The ERAL instruction is guaranteed at  $V_{cc} = +4.5V$  to  $+6.0V$ .

The DO pin indicates the  $\overline{READY}/\overline{BUSY}$  status of the device if CS is brought high after a minimum of 250 ns low ( $T_{CSL}$ ) and before the entire write cycle is complete.

The ERAL cycle takes 15 ms maximum (8 ms typical).

## 2.9 Write All (WRAL)

The WRAL instruction will write the entire memory array with the data specified in the command. The WRAL cycle is completely self-timed and commences at the falling edge of the CS. Clocking of the CLK pin is not necessary after the device has entered the self clocking mode. The WRAL command does include an automatic ERAL cycle for the device. Therefore, the WRAL instruction does not require an ERAL instruction but the chip must be in the EWEN status. The WRAL instruction is guaranteed at  $V_{cc} = +4.5V$  to  $+6.0V$ .

The DO pin indicates the  $\overline{READY}/\overline{BUSY}$  status of the device if CS is brought high after a minimum of 250 ns low ( $T_{CSL}$ ).

The WRAL cycle takes 30 ms maximum (16 ms typical).

**FIGURE 2-1: SYNCHRONOUS DATA TIMING**

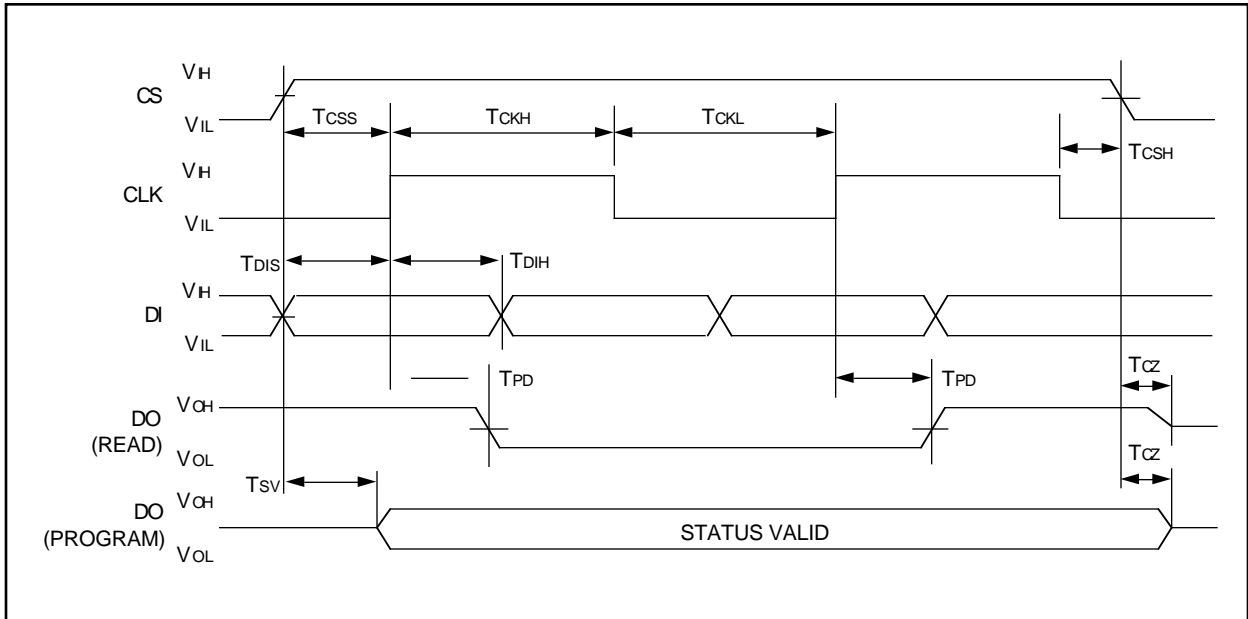

**FIGURE 2-2: READ TIMING**

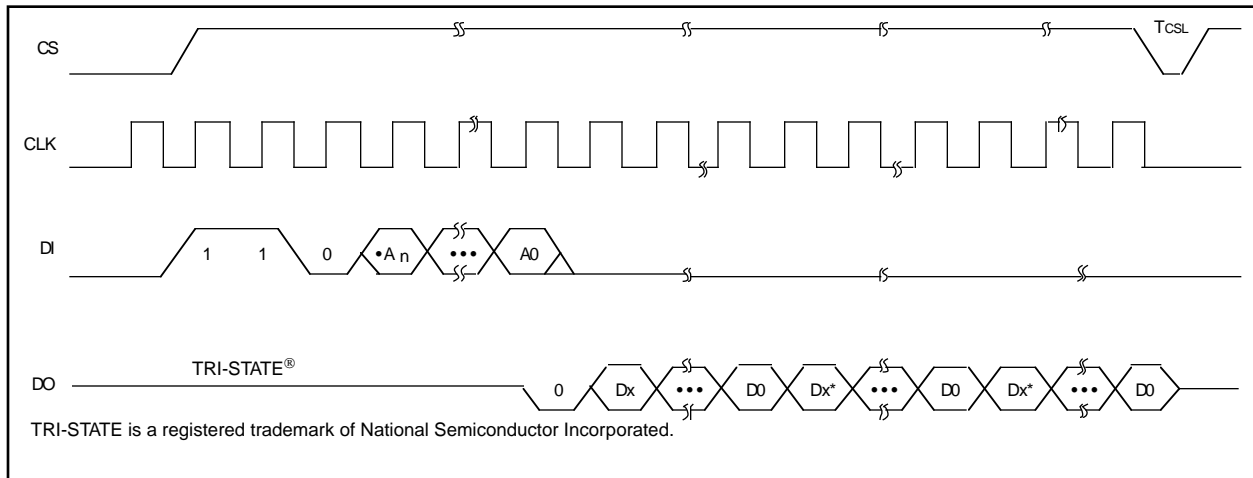

**FIGURE 2-3: EWEN TIMING**

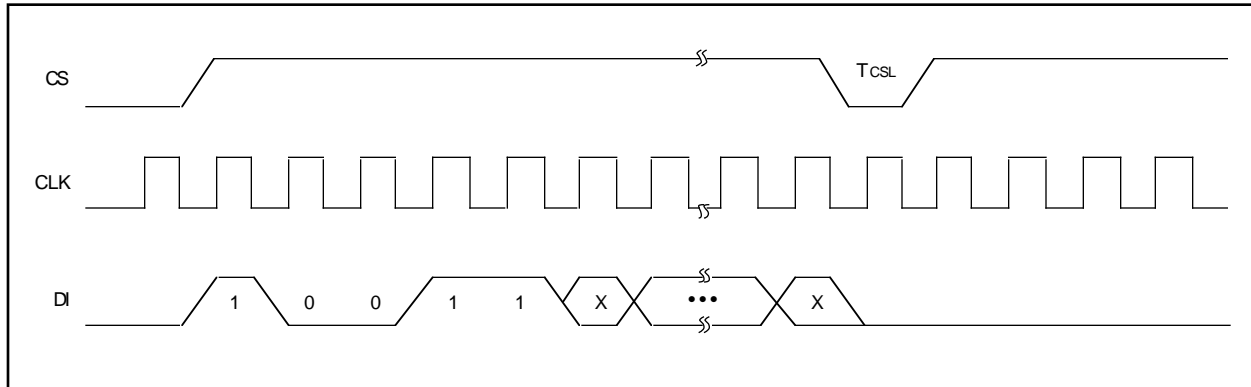

**FIGURE 2-4: EWDS TIMING**

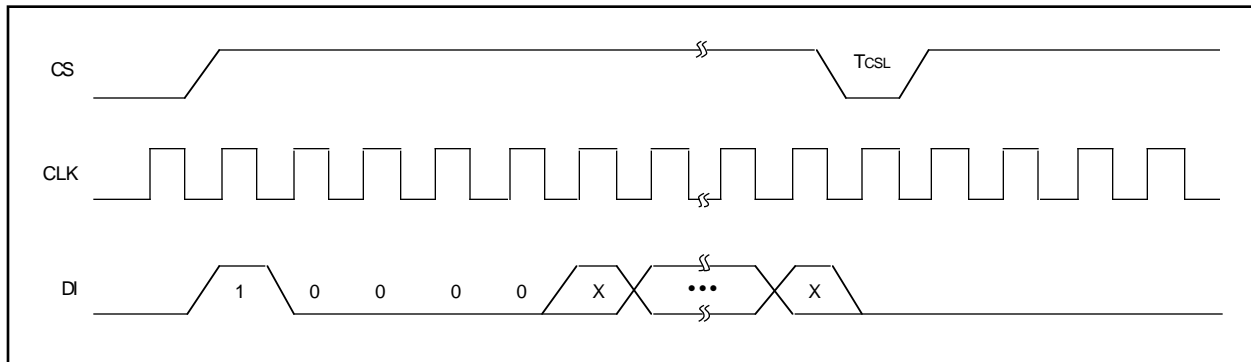

**FIGURE 2-5: WRITE TIMING**

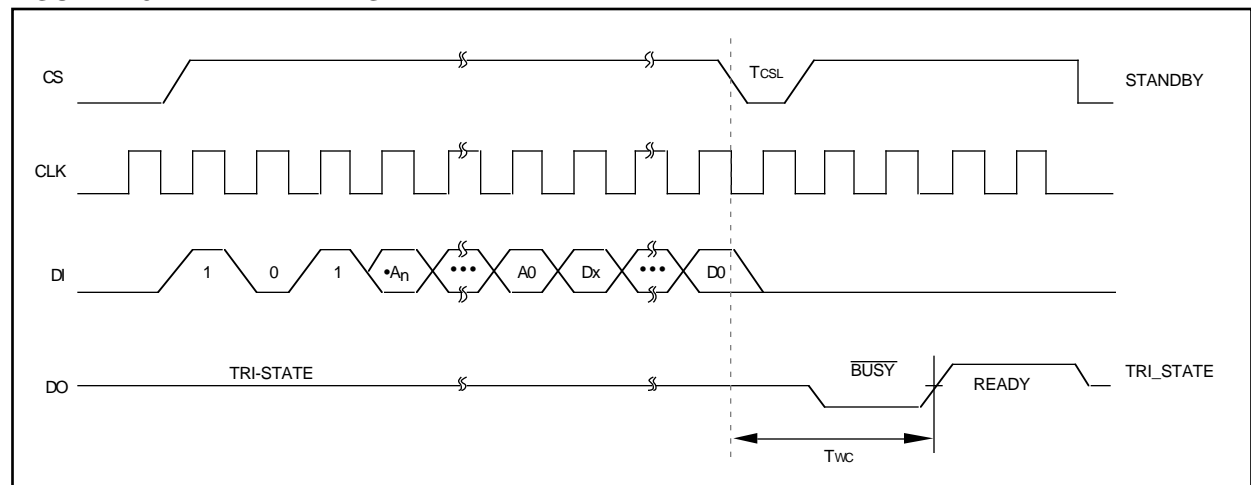

**FIGURE 2-6: WRAL TIMING**

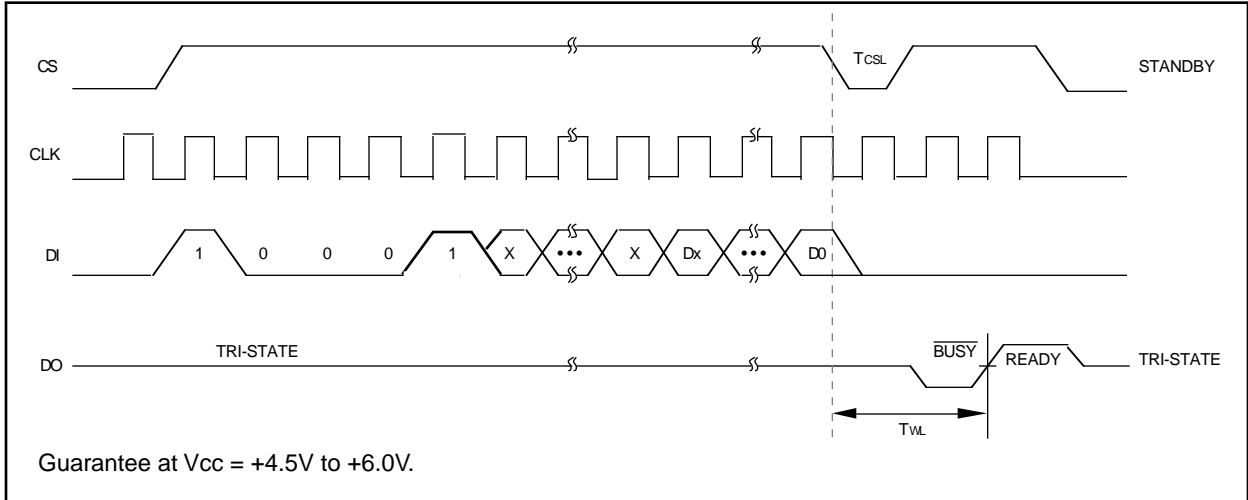

**FIGURE 2-7: ERASE TIMING**

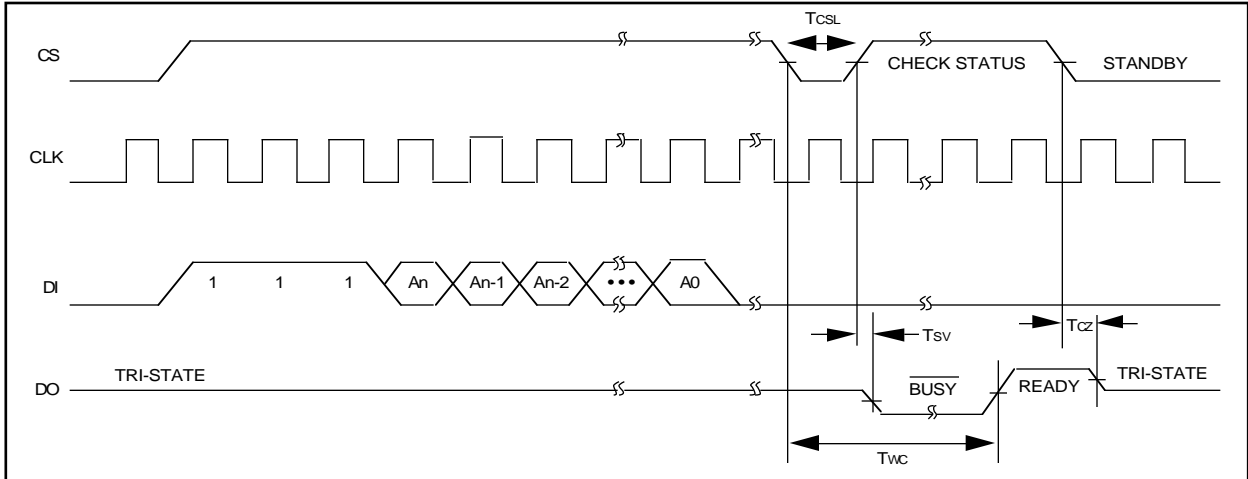

**FIGURE 2-8: ERAL TIMING**

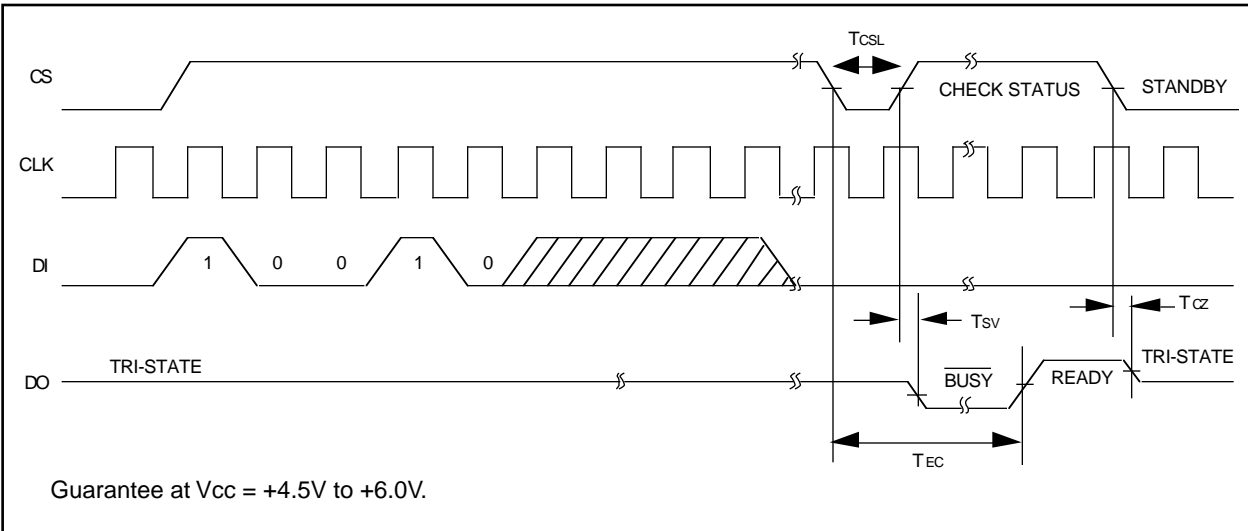

## 3.0 PIN DESCRIPTION

### 3.1 Chip Select (CS)

A HIGH level selects the device. A LOW level deselects the device and forces it into standby mode. However, a programming cycle which is already initiated and/or in progress will be completed, regardless of the CS input signal. If CS is brought LOW during a program cycle, the device will go into standby mode as soon as the programming cycle is completed.

CS must be LOW for 250 ns minimum (TCSL) between consecutive instructions. If CS is LOW, the internal control logic is held in a RESET status.

### 3.2 Serial Clock (CLK)

The Serial Clock is used to synchronize the communication between a master device and the 93LCXX. Opcode, address, and data bits are clocked in on the positive edge of CLK. Data bits are also clocked out on the positive edge of CLK.

CLK can be stopped anywhere in the transmission sequence (at HIGH or LOW level) and can be continued anytime with respect to clock HIGH time (TCKH) and clock LOW time (TCKL). This gives the controlling master freedom in preparing opcode, address, and data.

CLK is a "Don't Care" if CS is LOW (device deselected). If CS is HIGH, but START condition has not been detected, any number of clock cycles can be received by the device without changing its status (i.e., waiting for START condition).

CLK cycles are not required during the self-timed WRITE (i.e., auto ERASE/WRITE) cycle.

After detection of a start condition the specified number of clock cycles (respectively LOW to HIGH transitions of CLK) must be provided. These clock cycles are required to clock in all required opcode, address, and data bits before an instruction is executed (see instruction set truth table). CLK and DI then become don't care inputs waiting for a new start condition to be detected.

<b>Note:</b> CS must go LOW between consecutive instructions.
---

### 3.3 Data In (DI)

Data In is used to clock in a START bit, opcode, address, and data synchronously with the CLK input.

### 3.4 Data Out (DO)

Data Out is used in the READ mode to output data synchronously with the CLK input (TPD after the positive edge of CLK).

This pin also provides READY/ $\overline{\text{BUSY}}$  status information during ERASE and WRITE cycles. READY/ $\overline{\text{BUSY}}$  status information is available on the DO pin if CS is brought HIGH after being LOW for minimum chip select LOW time (TCSL) and an ERASE or WRITE operation has been initiated.

The status signal is not available on DO, if CS is held LOW or HIGH during the entire WRITE or ERASE cycle. In all other cases DO is in the HIGH-Z mode. If status is checked after the WRITE/ERASE cycle, a pull-up resistor on DO is required to read the READY signal.

### 3.5 Organization (ORG)

When ORG is connected to Vcc or floated, the (x16) memory organization is selected. When ORG is tied to Vss, the (x8) memory organization is selected. ORG can only be floated for clock speeds of 1 MHz or less for the (X16) memory organization. For clock speeds greater than 1 MHz, ORG must be tied to Vcc or Vss.



**NOTES:**

# 93LC46/56/66

---

---

NOTES:

# 93LC46/56/66

## 93LC46/56/66 Product Identification System

To order or to obtain information, e.g., on pricing or delivery, please use the listed part numbers, and refer to the factory or the listed sales offices.

<b>93LC46/56/66</b> - <b>/P</b>		<b>Package:</b>	P	= Plastic DIP (300 mil Body), 8-lead
			SN	= Plastic SOIC (150 mil Body), 8-lead
			SM	= Plastic SOIC (207 mil Body), 8-lead
			SL	= Plastic SOIC (150 mil Body), 14-lead
		<b>Temperature Range:</b>	Blank	= 0°C to +70°C
			I	= -40°C to +85°C
		<b>Device:</b>	93LC46/56/66	Microwire Serial EEPROM
			93LC56X/66X	Microwire Serial EEPROM in alternate pinouts (SN package only)
			93LC46T/56T/66T	Microwire Serial EEPROM (Tape and Reel)
			93LC56XT/66XT	Microwire Serial EEPROM (Tape and Reel)

## Sales and Support

Products supported by a preliminary Data Sheet may possibly have an errata sheet describing minor operational differences and recommended workarounds. To determine if an errata sheet exists for a particular device, please contact one of the following:

1. Your local Microchip sales office (see next page)
2. The Microchip Corporate Literature Center U.S. FAX: (602) 786-7277
3. The Microchip's Bulletin Board, via your local CompuServe number (CompuServe membership NOT required).

Please specify which device, revision of silicon and Data Sheet (include Literature #) you are using.

For latest version information and upgrade kits for Microchip Development Tools, please call 1-800-755-2345 or 1-602-786-7302.

---

---

# WORLDWIDE SALES & SERVICE

---

---

## AMERICAS

### Corporate Office

Microchip Technology Inc.  
2355 West Chandler Blvd.  
Chandler, AZ 85224-6199  
Tel: 602 786-7200 Fax: 602 786-7277  
Technical Support: 602 786-7627  
Web: <http://www.microchip.com>

### Atlanta

Microchip Technology Inc.  
500 Sugar Mill Road, Suite 200B  
Atlanta, GA 30350  
Tel: 770 640-0034 Fax: 770 640-0307

### Boston

Microchip Technology Inc.  
5 Mount Royal Avenue  
Marlborough, MA 01752  
Tel: 508 480-9990 Fax: 508 480-8575

### Chicago

Microchip Technology Inc.  
333 Pierce Road, Suite 180  
Itasca, IL 60143  
Tel: 708 285-0071 Fax: 708 285-0075

### Dallas

Microchip Technology Inc.  
14651 Dallas Parkway, Suite 816  
Dallas, TX 75240-8809  
Tel: 972 991-7177 Fax: 972 991-8588

### Dayton

Microchip Technology Inc.  
Suite 150  
Two Prestige Place  
Miamisburg, OH 45342  
Tel: 513 291-1654 Fax: 513 291-9175

### Los Angeles

Microchip Technology Inc.  
18201 Von Karman, Suite 1090  
Irvine, CA 92612  
Tel: 714 263-1888 Fax: 714 263-1338

### New York

Microchip Technology Inc.  
150 Motor Parkway, Suite 416  
Hauppauge, NY 11788  
Tel: 516 273-5305 Fax: 516 273-5335

### San Jose

Microchip Technology Inc.  
2107 North First Street, Suite 590  
San Jose, CA 95131  
Tel: 408 436-7950 Fax: 408 436-7955

### Toronto

Microchip Technology Inc.  
5925 Airport Road, Suite 200  
Mississauga, Ontario L4V 1W1, Canada  
Tel: 905 405-6279 Fax: 905 405-6253

## ASIA/PACIFIC

### Hong Kong

Microchip Technology  
RM 3801B, Tower Two  
Metroplaza  
223 Hing Fong Road  
Kwai Fong, N.T. Hong Kong  
Tel: 852 2 401 1200 Fax: 852 2 401 3431

### India

Microchip Technology  
No. 6, Legacy, Convent Road  
Bangalore 560 025 India  
Tel: 91 80 526 3148 Fax: 91 80 559 9840

### Korea

Microchip Technology  
168-1, Youngbo Bldg. 3 Floor  
Samsung-Dong, Kangnam-Ku,  
Seoul, Korea  
Tel: 82 2 554 7200 Fax: 82 2 558 5934

### Shanghai

Microchip Technology  
Unit 406 of Shanghai Golden Bridge Bldg.  
2077 Yan'an Road West, Hongjiao District  
Shanghai, Peoples Republic of China  
Tel: 86 21 6275 5700  
Fax: 011 86 21 6275 5060

### Singapore

Microchip Technology  
200 Middle Road  
#10-03 Prime Centre  
Singapore 188980  
Tel: 65 334 8870 Fax: 65 334 8850

### Taiwan, R.O.C

Microchip Technology  
10F-1C 207  
Tung Hua North Road  
Taipei, Taiwan, ROC  
Tel: 886 2 717 7175 Fax: 886 2 545 0139

## EUROPE

### United Kingdom

Arizona Microchip Technology Ltd.  
Unit 6, The Courtyard  
Meadow Bank, Furlong Road  
Bourne End, Buckinghamshire SL8 5AJ  
Tel: 44 1628 850303 Fax: 44 1628 850178

### France

Arizona Microchip Technology SARL  
Zone Industrielle de la Bonde  
2 Rue du Buisson aux Fraises  
91300 Massy - France  
Tel: 33 1 69 53 63 20 Fax: 33 1 69 30 90 79

### Germany

Arizona Microchip Technology GmbH  
Gustav-Heinemann-Ring 125  
D-81739 Muenchen, Germany  
Tel: 49 89 627 144 0 Fax: 49 89 627 144 44

### Italy

Arizona Microchip Technology SRL  
Centro Direzionale Colleone Pas Taurus 1  
Viale Colleoni 1  
20041 Agrate Brianza  
Milan Italy  
Tel: 39 39 6899939 Fax: 39 39 689 9883

### JAPAN

Microchip Technology Intl. Inc.  
Benex S-1 6F  
3-18-20, Shin Yokohama  
Kohoku-Ku, Yokohama  
Kanagawa 222 Japan  
Tel: 81 45 471 6166 Fax: 81 45 471 6122

11/7/96



**MICROCHIP**

All rights reserved. © 1996, Microchip Technology Incorporated, USA. 11/96



Printed on recycled paper.

Information contained in this publication regarding device applications and the like is intended through suggestion only and may be superseded by updates. No representation or warranty is given and no liability is assumed by Microchip Technology Incorporated with respect to the accuracy or use of such information, or infringement of patents or other intellectual property rights arising from such use or otherwise. Use of Microchip's products as critical components in life support systems is not authorized except with express written approval by Microchip. No licenses are conveyed, implicitly or otherwise, under any intellectual property rights. The Microchip logo and name are registered trademarks of Microchip Technology Inc. All rights reserved. All other trademarks mentioned herein are the property of their respective companies.