

Jan De Nayerlaan, 5
B-2860 Sint-Katelijne-Waver
Belgium
www.denayer.be

Spread Spectrum (SS)

introduction

ir. J. Meel
jme@denayer.wenk.be

Studiedag Spread Spectrum - 6 okt. '99

In the period of nov. 1997 - nov. 1999 a 'Spread Spectrum' project was worked out at the polytechnic 'DE NAYER instituut'. The goal of this project was the hardware/software implementation of a Direct Sequence Spread Spectrum (CDMA) demonstrator in the 2.4 GHz ISM band. A measurement environment (Vector Signal Analyzer, IQ-modulator, Bit Error Rate Tester) was build out, resulting in a set of experiments based on this demonstrator. The project results where communicated with SMO's (Small and Medium Organisations) interested in Spread Spectrum. These notes were used to introduce the SMO's in the subject of Spread Spectrum. This Spread Spectrum project was sponsored by:



Vlaams Instituut voor de bevordering van het Wetenschappelijk Technologisch onderzoek
in de industrie – (*Flemisch Gouvernement*)



Sirius Communications – Rotselaar - Belgium

CONTENTS

1. DEFINITION OF SPREAD SPECTRUM (SS)	3
2. BASIC PRINCIPLE OF SPREAD SPECTRUM SYSTEMS: DSSS AND FHSS	3
BASIC PRINCIPLE OF DIRECT SEQUENCE SPREAD SPECTRUM (DSSS)	5
3.1 MODULATION	6
3.2 DEMODULATION.....	7
3.2.1 $pn_r = pn_t$	7
3.2.2 $pn_r \neq pn_t$	8
4. PERFORMANCE IN THE PRESENCE OF INTERFERENCE	9
4.1 NARROWBAND INTERFERENCE.....	10
4.2 WIDEBAND INTERFERENCE	10
5. PSEUDO-NOISE SEQUENCES PN	12
RANDOM WHITE GAUSSIAN NOISE	12
PSEUDO-RANDOM NOISE.....	13
5.3 PROPERTIES OF PN SEQUENCES.....	13
TYPES.....	15
5.4.1 <i>m</i> -sequence	15
5.4.2 <i>Barker Code</i>	18
5.4.3 <i>Gold Codes</i>	18
<i>Hadamard-Walsh Codes</i>	21
6. TRANSMITTER ARCHITECTURE	22
7. RECEIVER ARCHITECTURE	22
PN DECORRELATORS	23
8.1 PN MATCHED FILTER	23
8.2 PN ACTIVE CORRELATOR (INTEGRATE AND DUMP).....	24
9. PN SYNCHRONIZATION	24
9.1 ACQUISITION PHASE (COARSE SYNCHRONIZATION)	25
9.1.1 <i>Serial Synchronization (Sliding Correlator)</i>	25
9.1.2 <i>Serial/Parallel Synchronization</i>	26
9.2 TRACKING PHASE (FINE SYNCHRONIZATION).....	27
10. MULTIPLE ACCESS	28
11. MULTIPATH CHANNELS	30
12. JAMMING	31
13. ISM BANDS	32
EVALUATION OF SS	33
15. REFERENCES	33

1. Definition of Spread Spectrum (SS)

A transmission technique in which a pseudo-noise code, independent of the information data, is employed as a modulation waveform to “spread” the signal energy over a bandwidth much greater than the signal information bandwidth. At the receiver the signal is “despread” using a synchronized replica of the pseudo-noise code.

2. Basic principle of Spread Spectrum Systems: DSSS and FHSS

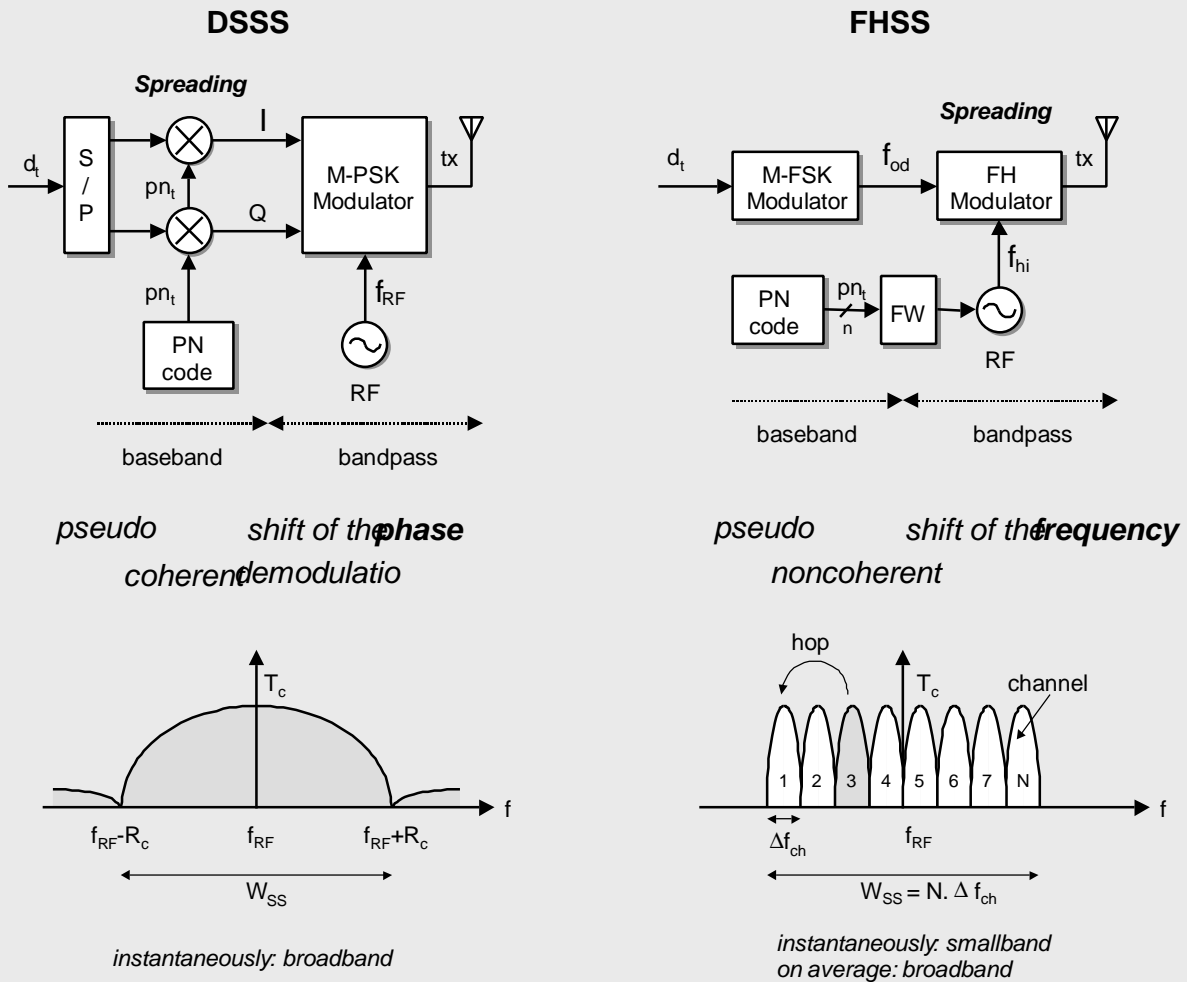

Direct Sequence Spread Spectrum (DSSS)

A pseudo-noise sequence pn_t generated at the modulator, is used in conjunction with an M-ary PSK modulation to shift the phase of the PSK signal pseudorandomly, at the chipping rate R_c ($=1/T_c$) a rate that is an integer multiple of the symbol rate R_s ($=1/T_s$).

The transmitted bandwidth is determined by the chip rate and by the baseband filtering. The implementation limits the maximum chip rate R_c (clock rate) and thus the maximum spreading.

The PSK modulation scheme requires a coherent demodulation.

A short-code system uses a PN code length equal to a data symbol. A long-code system uses a PN code length that is much longer than a data symbol, so that a different chip pattern is associated with each symbol.

Frequency Hopping Spread Spectrum

A pseudo-noise sequence pn_t generated at the modulator is used in conjunction with an M-ary FSK modulation to shift the carrier frequency of the FSK signal pseudorandomly, at the hopping rate R_h . The transmitted signal occupies a number of frequencies in time, each for a period of time $T_h (=1/R_h)$, referred to as dwell time. FHSS divides the available bandwidth into N channels and hops between these channels according to the PN sequence. At each frequency hop time the PN generator feeds the frequency synthesizer a frequency word FW (a sequence of n chips) which dictates one of 2^n frequency positions f_{hi} . Transmitter and receiver follow the same frequency hop pattern.

The transmitted bandwidth is determined by the lowest and highest hop positions and by the bandwidth per hop position (Δf_{ch}). For a given hop, the instantaneous occupied bandwidth is identical to bandwidth of the conventional M-FSK, which is typically much smaller than W_{ss} . So the FHSS signal is a narrowband signal, all transmission power is concentrated on one channel. Averaged over many hops, the FH/M-FSK spectrum occupies the entire spread spectrum bandwidth. Because the bandwidth of an FHSS system only depends on the tuning range, it can be hopped over a much wider bandwidth than an DSSS system.

Since the hops generally result in phase discontinuity (depending on the particular implementation) a noncoherent demodulation is done at the receiver.

With slow hopping there are multiple data symbols per hop and with fast hopping there are multiple hops per data symbol.

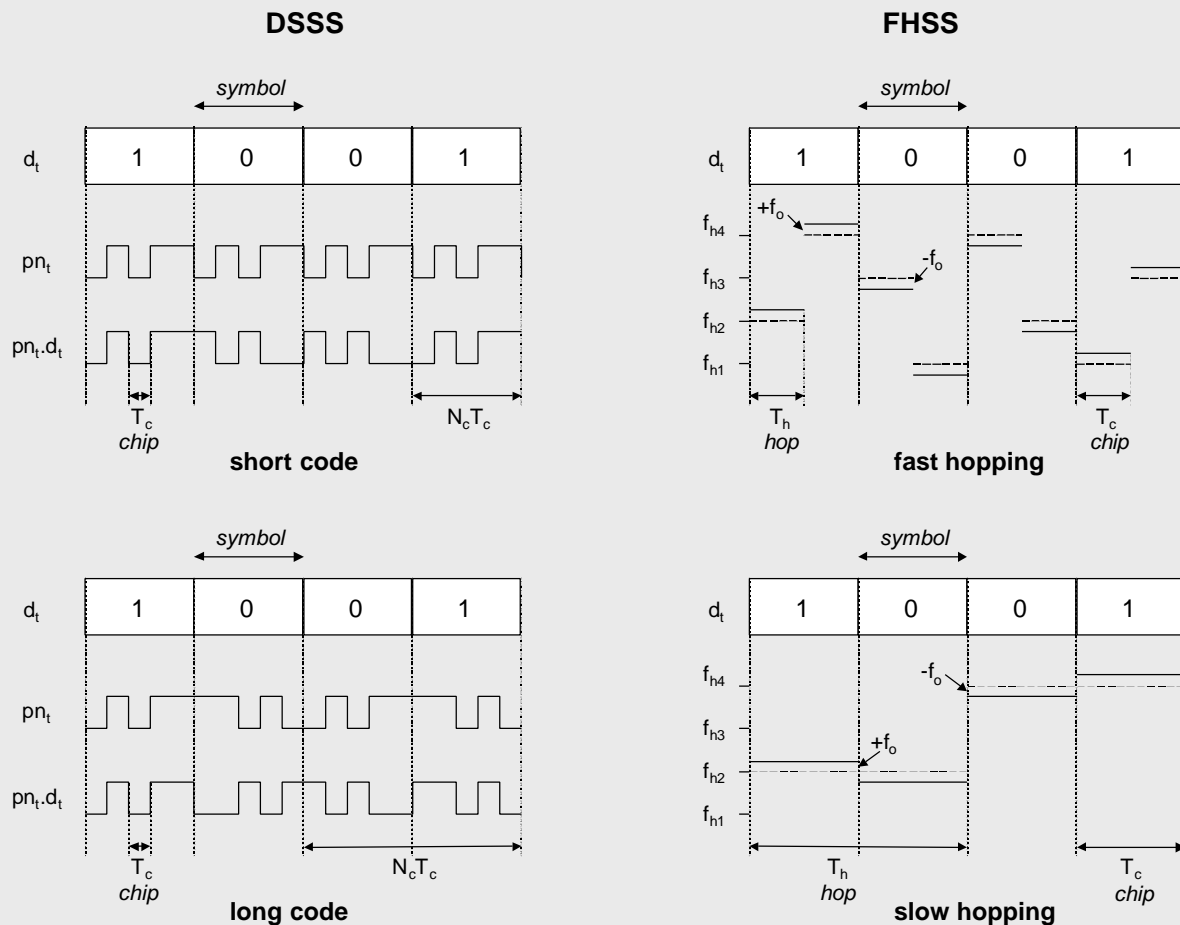

3. Basic principle of Direct Sequence Spread Spectrum (DSSS)

For BPSK modulation the building blocks of a DSSS system are:

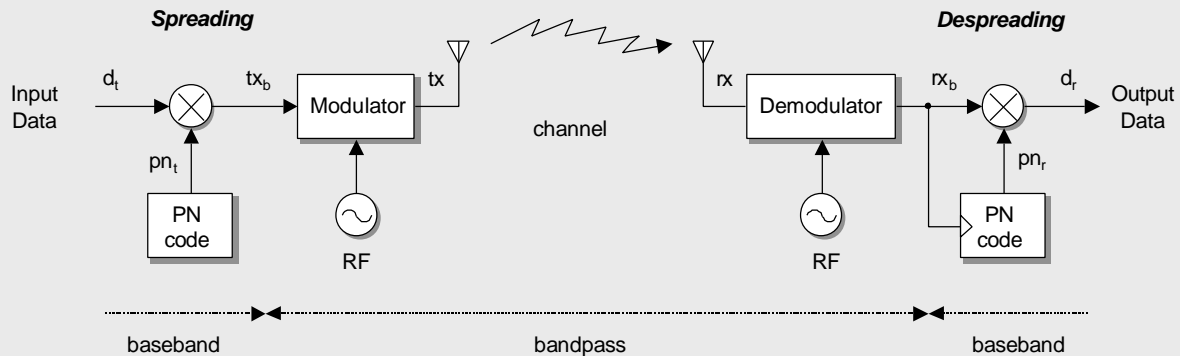

Input:

- Binary data d_t with symbol rate $R_s = 1/T_s$ (= bitrate R_b for BPSK)
- Pseudo-noise code pn_t with chip rate $R_c = 1/T_c$ (an integer of R_s)

Spreading:

In the transmitter, the binary data d_t (for BPSK, I and Q for QPSK) is 'directly' multiplied with the PN sequence pn_t , which is independent of the binary data, to produce the transmitted baseband signal tx_b :

$$tx_b = d_t \cdot pn_t$$

The effect of multiplication of d_t with a PN sequence is to spread the baseband bandwidth R_s of d_t to a baseband bandwidth of R_c .

Despreading:

The spread spectrum signal cannot be detected by a conventional narrowband receiver. In the receiver, the received baseband signal rx_b is multiplied with the PN sequence pn_r .

- If $pn_r = pn_t$ and synchronized to the PN sequence in the received data, then the recovered binary data is produced on d_r . The effect of multiplication of the spread spectrum signal rx_b with the PN sequence pn_t used in the transmitter is to despread the bandwidth of rx_b to R_s .
- If $pn_r \neq pn_t$, then there is no despreading action. The signal d_r has a spread spectrum. A receiver not knowing the PN sequence of the transmitter cannot reproduce the transmitted data.

To simplify the description of modulation and demodulation, the spread spectrum system is considered for baseband BPSK communication (without filtering) over an ideal channel.

3.1 Modulation

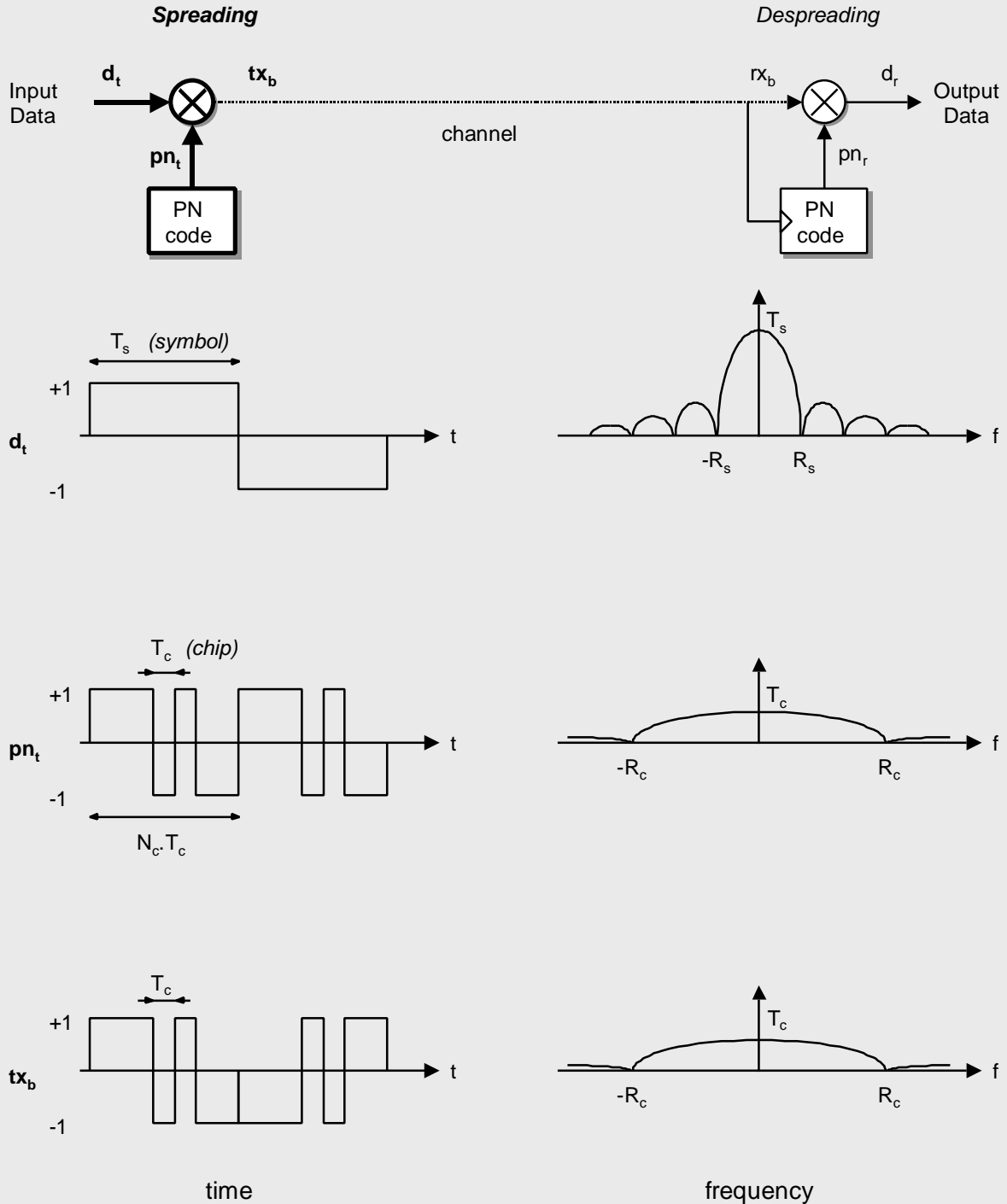

Spread spectrum systems are spreading the information signal d_t which has a BW_{info} , over a much larger bandwidth BW_{SS} :

$$BW_{info} \cong R_s \ll BW_{SS} \cong R_c$$

The SS-signal spectrum is white noise-like. The amplitude and thus the power in the SS-signal tx_b is the same as in the original information signal d_t . Due to the increased bandwidth of the SS-

signal the power spectral density must be lower. The bandwidth expansion factor, being the ratio of the chip rate R_c and the data symbol rate R_s , is usually selected to be an integer in practical SS systems:

$$SF = G_p = \frac{BW_{SS}}{BW_{info}} = \frac{R_c}{R_s} = \frac{T_b}{T_c} = N_c$$

3.2 Demodulation

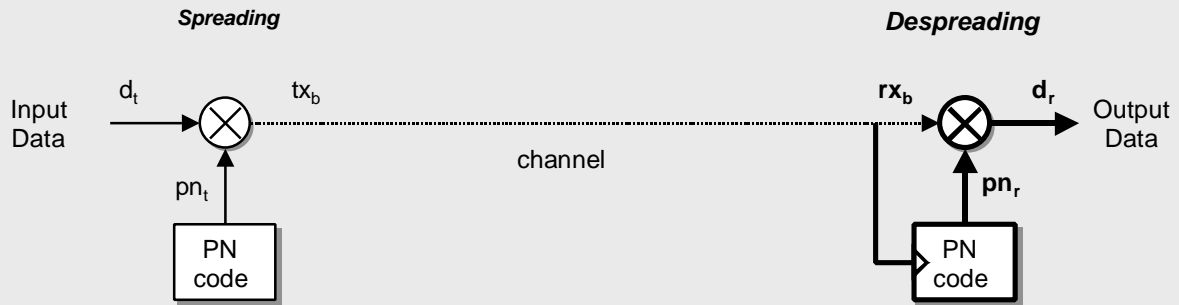

3.2.1 $pn_r = pn_t$

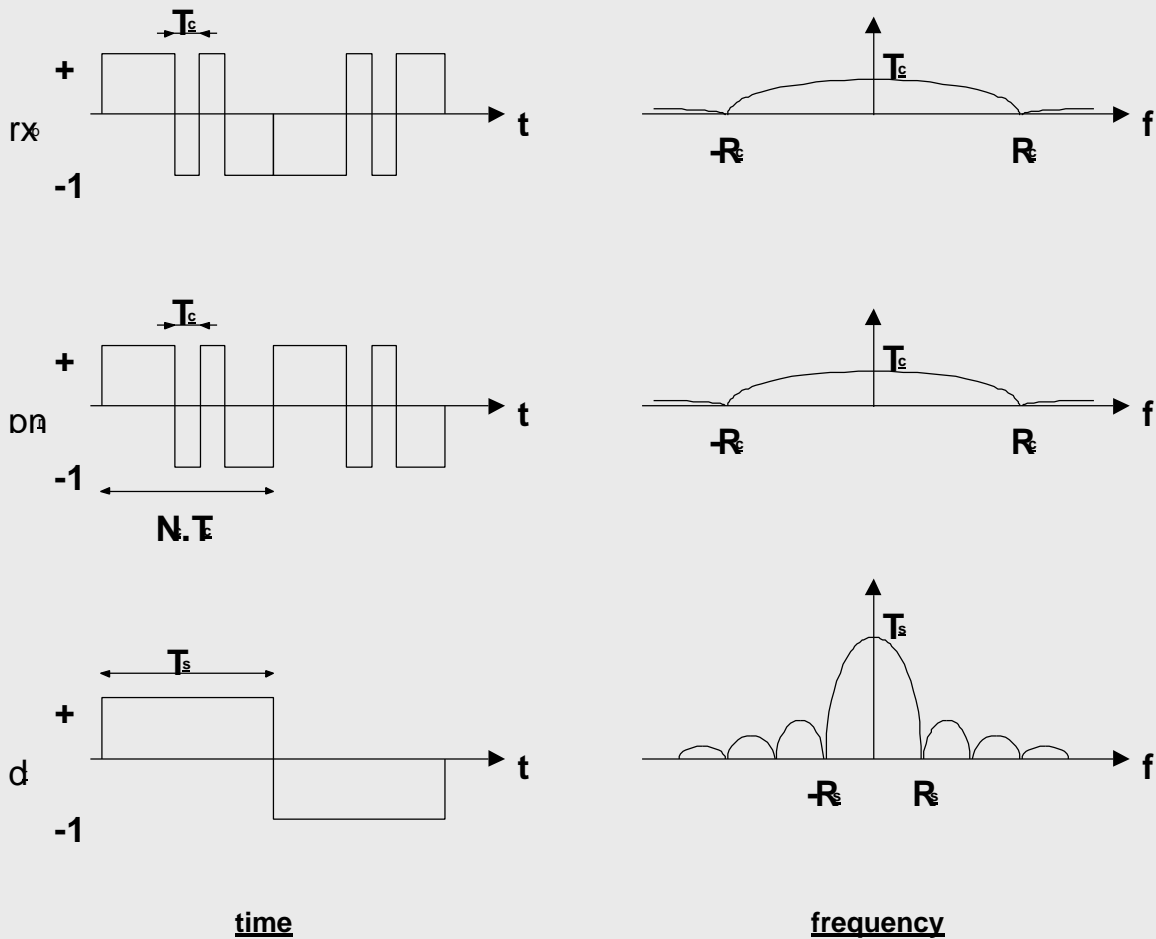

To demodulate, the received signal is multiplied by pn_r , this is the same PN sequence as pn_t (the pseudo-noise code used in the transmitter), synchronized to the PN sequence in the received signal rx_b . This operation is called (spectrum) despreading, since the effect is to undo the spreading operation at the transmitter.

The multiplier output in the receiver is then (since $pn_r =$ synchronized pn_t) :

$$d_r = rx_b \cdot pn_r = (d_t \cdot pn_t) \cdot pn_t$$

The PN sequence pn_t alternates between the levels -1 and +1, in the example:

$$pn_t = +1 +1 +1 -1 +1 -1 -1$$

The alternation is destroyed when the PN sequence pn_t is multiplied with itself (perfectly synchronized), because:

$$pn_t \cdot pn_t = +1 \quad \text{for all } t$$

Thus:

$$\text{autocorrelation } Ra(t=0) = \text{average}(pn_t \cdot pn_t) = +1$$

The data signal is reproduced at the multiplier output:

$$d_r = d_t$$

If the PN sequence at the receiver is not synchronized properly to the received signal, the data cannot be recovered.

3.2.2 $pn_r \neq pn_t$

If the received signal is multiplied by a PN sequence pn_r , different from the one used in the modulator, the multiplier output becomes:

$$d_r = rx_b \cdot pn_r = (d_t \cdot pn_t) \cdot pn_r$$

In the receiver, detection of the desired signal is achieved by correlation against a local reference PN sequence. For secure communications in a multi-user environment, the transmitted data d_t may not be recovered by a user that doesn't know the PN sequence pn_t used at the transmitter. Therefore:

$$\text{crosscorrelation } Rc(t) = \text{average}(pn_t \cdot pn_r) \ll 1 \quad \text{for all } \tau$$

is required. This orthogonal property of the allocated spreading codes, means that the output of the correlator used in the receiver is approximately zero for all except the desired transmission.

4. Performance in the presence of interference

To simplify the influence of interference, the spread spectrum system is considered for baseband BPSK communication (without filtering).

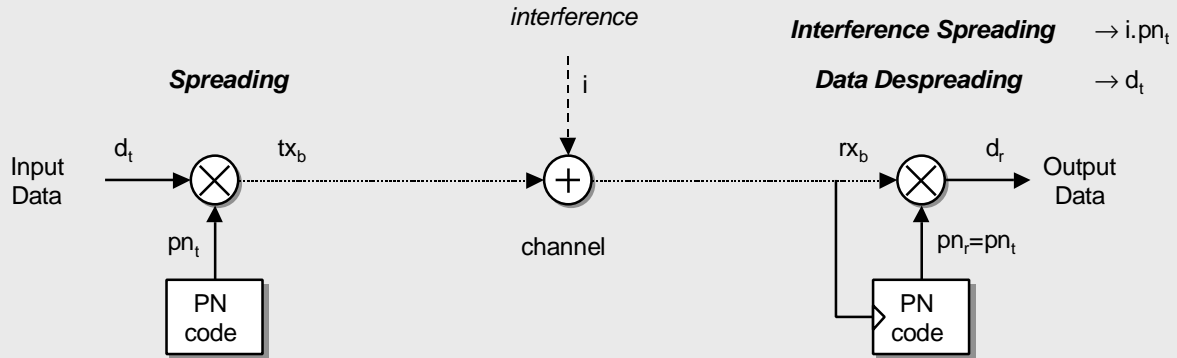

The received signal rx_b consists of the transmitted signal tx_b plus an additive interference i (noise, other users, jammer, ...):

$$rx_b = tx_b + i = d_t \cdot pn_t + i$$

To recover the original data d_t , the received signal rx_b is multiplied with a locally generated PN sequence pn_r that is an exact replica of that used in the transmitter (that is $pn_r = pn_t$ and synchronized). The multiplier output is therefore given by:

$$d_r = rx_b \cdot pn_t = d_t \cdot pn_t \cdot pn_t + i \cdot pn_t$$

The data signal d_t is multiplied *twice* by the PN sequence pn_t , whereas the unwanted interference i is multiplied only *once*.

Due to the property of the PN sequence:

$$pn_t \cdot pn_t = +1 \quad \text{for all } t$$

The multiplier output becomes:

$$d_r = d_t + i \cdot pn_t$$

The data signal d_t is reproduced at the multiplier output in the receiver, except for the interference represented by the additive term $i \cdot pn_t$. Multiplication of the interference i by the locally generated PN sequence, means that the spreading code will affect the interference just as it did with the information bearing signal at the transmitter. Noise and interference, being uncorrelated with the PN sequence, become noise-like, increase in bandwidth and decrease in power density after the multiplier.

After despreading, the data component d_t is narrow band (R_s) whereas the interference component is wideband (R_c). By applying the d_r signal to a baseband (low-pass) filter with a bandwidth just large enough to accommodate the recovery of the data signal, most of the interference component i is filtered out. The effect of the interference is reduced by the processing gain (G_p).

4.1 Narrowband interference

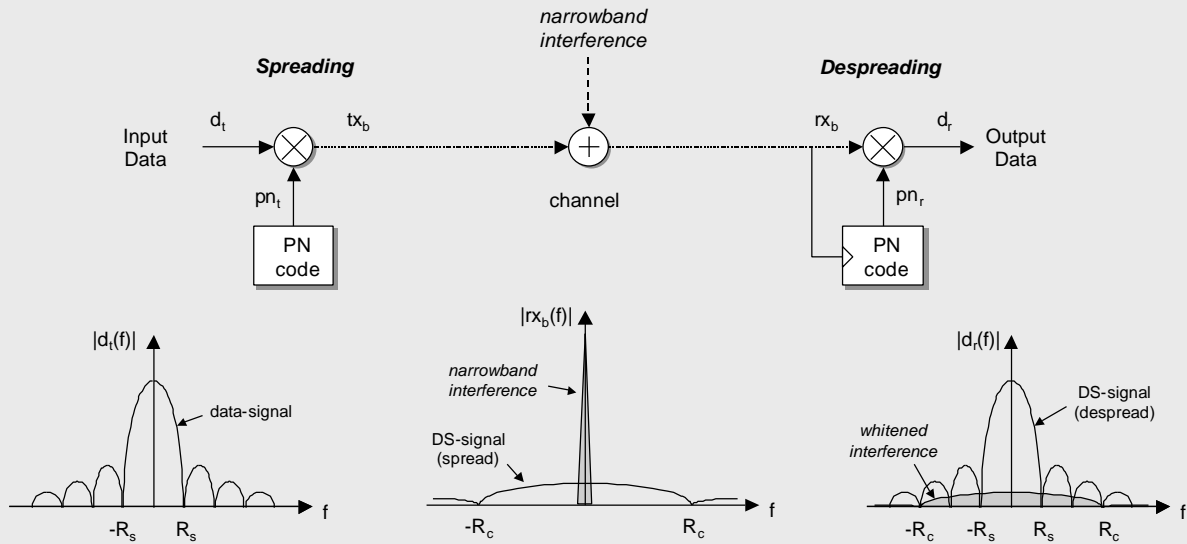

The narrowband noise is spread by the multiplication with the PN sequence pn_r of the receiver. The power density of the noise is reduced with respect to the despread data signal. Only $1/G_p$ of the original noise power is left in the information baseband (R_s). Spreading and despreading enables a bandwidth trade for processing gain against narrow band interfering signals. Narrowband interference would disable conventional narrowband receivers.

The essence behind the interference rejection capability of a spread spectrum system: the useful signal (data) gets multiplied twice by the PN sequence, but the interference signal gets multiplied only once.

4.2 Wideband interference

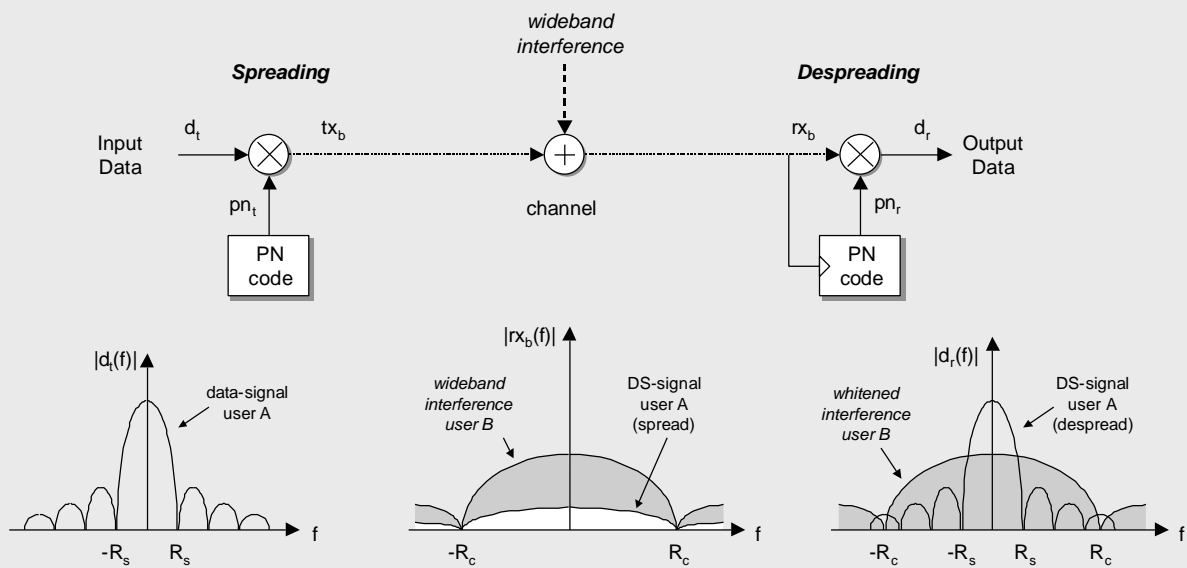

Multiplication of the received signal with the PN sequence of the receiver gives a selective despread of the data signal (smaller bandwidth, higher power density). The interference signal is uncorrelated with the PN sequence and is spread.

Origin of wideband noise:

- Multiple Spread Spectrum users: multiple access mechanism.
- Gaussian Noise: There is no increase in SNR with spread spectrum. The larger channel bandwidth (R_c instead of R_s) increases the received noise power with G_p :

$$N_{\text{info}} = N_0 \cdot BW_{\text{info}} \rightarrow N_{\text{SS}} = N_0 \cdot BW_{\text{SS}} = N_{\text{info}} \cdot G_p$$

The spread spectrum signal has a lower power density than the directly transmitted signal.

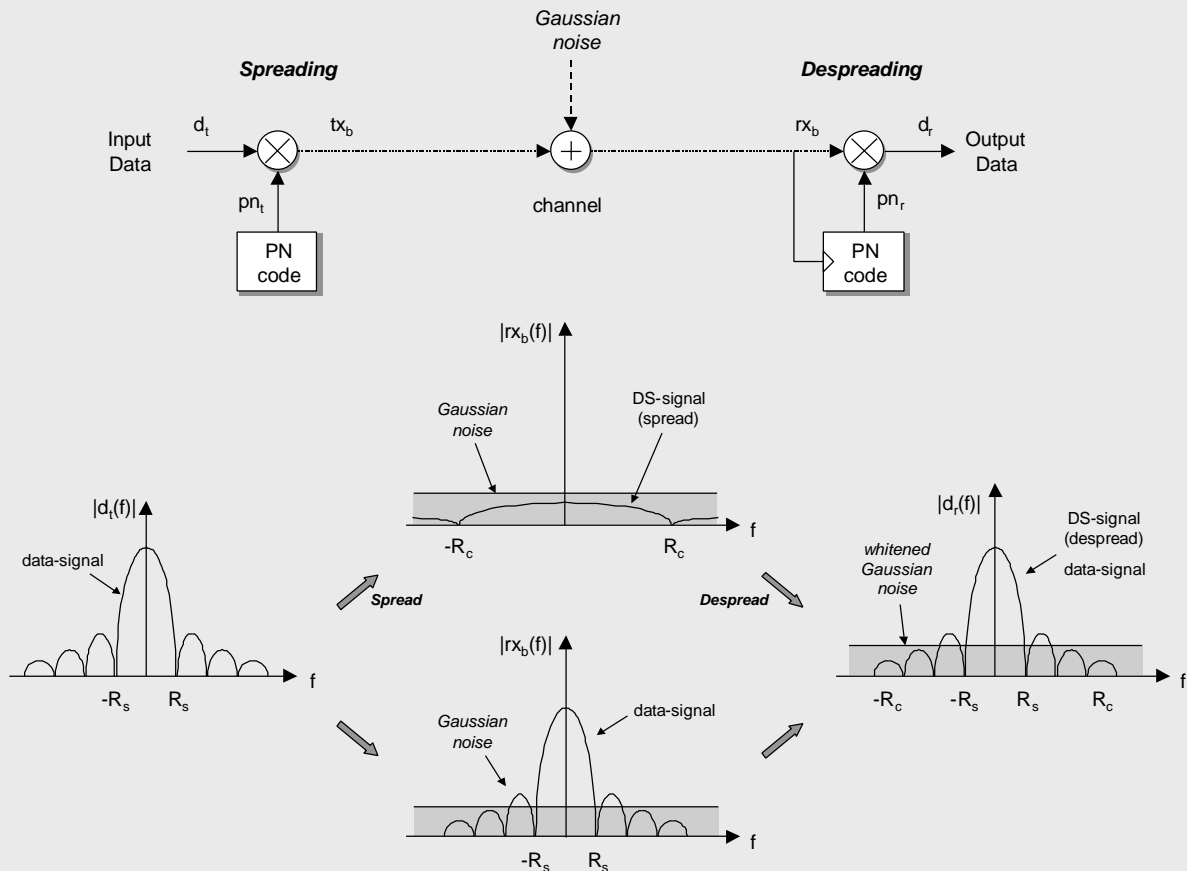

5. Pseudo-Noise Sequences PN

5.1 Random White Gaussian Noise

Zero-mean White Gaussian Noise (WGN) has the same power spectral density $G_{WGN}(f)$ for all frequencies. The adjective 'white' is used in the sense that white light contains equal amounts of all frequencies within the visible band of electromagnetic radiation.

The autocorrelation function of WGN is given by the inverse Fourier transform of the noise power spectral density $G_{WGN}(f)$:

$$Ra_{WGN}(\tau) = \int_{-\infty}^{+\infty} GWN(t).GWN(t + \tau) dt = F^{-1}\{G_{WGN}(f)\} = \frac{N_0}{2} \delta(\tau)$$

The autocorrelation function $Ra_{WGN}(\tau)$ is zero for $\tau \neq 0$. This means that any two different samples of WGN, no matter how close together in time they are taken, are uncorrelated. The noise signal $WGN(t)$ is totally decorrelated from its time-shifted version for any $\tau \neq 0$.

The amplitude of 'integrated' (bandlimited) WGN has a Gaussian probability density distribution $p(WGN_i)$:

$$p(WGN_i) = \frac{1}{\sigma\sqrt{2\pi}} e^{\left[-\frac{1}{2}\left(\frac{n}{\sigma}\right)^2\right]}$$

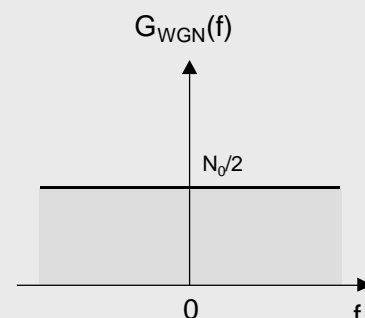
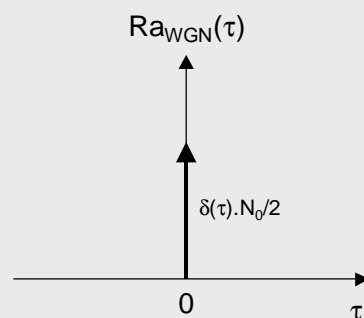
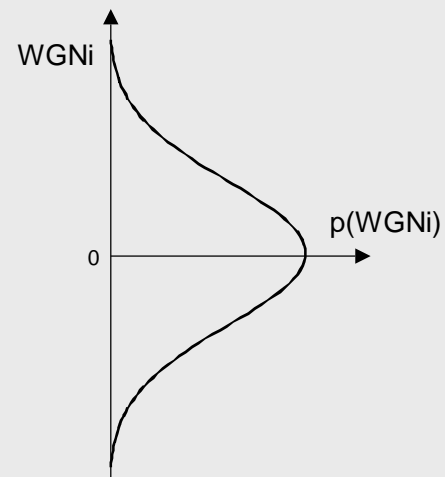
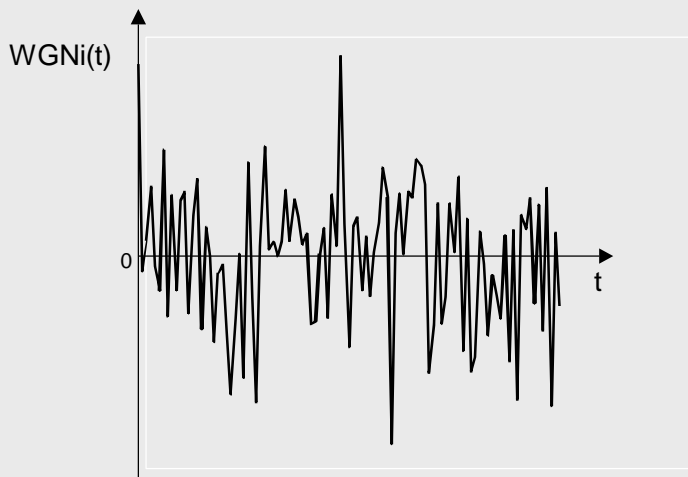

5.2 Pseudo-Random Noise

A Pseudo-Noise (PN) code sequence acts as a noiselike (but deterministic) carrier used for bandwidth spreading of the signal energy. The selection of a good code is important, because type and length of the code sets bounds on the system capability.

The PN code sequence is a Pseudo-Noise or Pseudo-Random sequence of 1's and 0's, but not a real random sequence (because periodic). Random signals cannot be predicted.

The autocorrelation of a PN code has properties similar to those of white noise.

Pseudo-Random:

- Not random, but it looks randomly for the user who doesn't know the code.
- Deterministic, periodical signal that is known to both the transmitter and the receiver. The longer the period of the PN spreading code, the closer will the transmitted signal be a truly random binary wave, and the harder it is to detect.
- Statistical properties of sampled white-noise.

Length:

- Short code: The same PN sequence for each data symbol ($N_c \cdot T_c = T_s$).
- Long code: The PN sequence period is much longer than the data symbol, so that a different chip pattern is associated with each symbol ($N_c \cdot T_c \gg T_s$).

5.3 Properties of PN Sequences

Balance Property

In each period of the sequence the number of binary ones differs from the number of binary zeros by at most one digit (for N_c odd).

$$pn = +1 +1 +1 -1 +1 -1 -1 \rightarrow \Sigma = +1$$

When modulating a carrier with a PN coding sequence, one-zero balance (DC component) can limit the degree of carrier suppression obtainable, because carrier suppression is dependant on the symmetry of the modulating signal.

Run-length Distribution

A run is a sequence of a single type of binary digits. Among the runs of ones and zeros in each period it is desirable that about one-half the runs of each type are of length 1, about one-fourth are of length 2, one-eighth are of length 3, and so on.

Autocorrelation

The origin of the name pseudo-noise is that the digital signal has an autocorrelation function which is very similar to that of a white noise signal: impuls like.

The autocorrelation function for the *periodic* sequence pn is defined as the number of agreements less the number of disagreements in a term by term comparison of one full period of the sequence with a *cyclic* shift (position τ) of the sequence itself:

$$Ra(\tau) = \int_{-N_c T_c / 2}^{N_c T_c / 2} pn(t) \cdot pn(t + \tau) dt$$

It is best if $Ra(\tau)$ is not larger than one count if not synchronized ($\tau=0$).

$$\begin{aligned}
 pn(0) &= +1 +1 +1 -1 +1 -1 -1 \\
 \underline{pn(0)} &= \underline{+1 +1 +1 -1 +1 -1 -1} \\
 &+1 +1 +1 +1 +1 +1 +1 = \Sigma = 7 = Ra(\tau=0)
 \end{aligned}$$

$$\begin{aligned}
 pn(0) &= +1 +1 +1 -1 +1 -1 -1 \\
 \underline{pn(1)} &= \underline{+1 +1 -1 +1 -1 -1 +1} \\
 &+1 +1 -1 -1 -1 +1 -1 = \Sigma = -1 = Ra(\tau=1)
 \end{aligned}$$

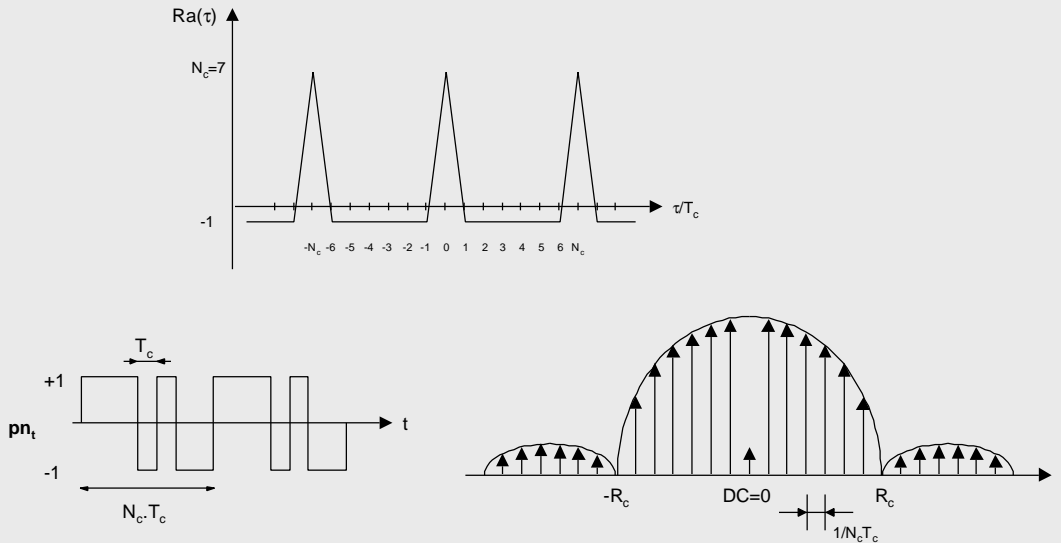

For PN sequences the autocorrelation has a large peaked maximum (only) for perfect synchronization of two identical sequences (like white noise). The synchronization of the receiver is based on this property.

Frequency Spectrum

Due to the periodic nature of the PN sequence the frequency spectrum has spectral lines which become closer to each other with increasing sequence length N_c . Each line is further smeared by data scrambling, which spreads each spectral line and further fills in between the lines to make the spectrum more nearly continuous. The DC component is determined by the zero-one balance of the PN sequence.

Cross-correlation:

Cross-correlation describes the interference between codes pn_i and pn_j :

$$R_c(\tau) = \int_{-N_c T_c/2}^{N_c T_c/2} pn_i(t) \cdot pn_j(t + \tau) dt$$

Cross-correlation is the measure of agreement between two different codes pn_i and pn_j . When the cross-correlation $R_c(\tau)$ is zero for all τ , the codes are called *orthogonal*. In CDMA multiple users occupy the same RF bandwidth and transmit simultaneous. When the user codes are orthogonal, there is no interference between the users after despreading and the privacy of the communication of each user is protected.

In practice, the codes are not perfectly orthogonal; hence the cross-correlation between user codes introduces performance degradation (increased noise power after despreading), which limits the maximum number of simultaneous users.

5.4 Types

5.4.1 m-sequence

A Simple Shift Register Generator (SSRG) has all the feedback signals returned to a single input of a shift register (delay line). The SSRG is *linear* if the feedback function can be expressed as a modulo-2 sum (xor).

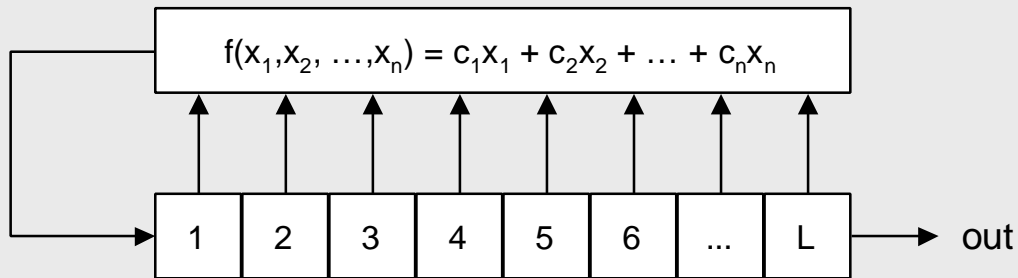

The feedback function $f(x_1, x_2, \dots, x_n)$ is a modulo-2 sum of the contents x_i of the shift register cells with c_i being the feedback connection coefficients ($c_i=0$ =open, $c_i=1$ =connect).

An SSRG with L flip-flops produces sequences that depend upon register length L , feedback tap connections and initial conditions. When the period (length) of the sequence is exactly $N_c = 2^L - 1$, the PN sequence is called a *maximum-length sequence* or simply an *m-sequence*.

An m-sequence generated from a linear SSRG has an *even number of taps*.

If an L -stage SSRG has feedback taps on stages L, k, m and has sequence $\dots, a_i, a_{i+1}, a_{i+2}, \dots$ then the *reverse SSRG* has feedback taps on $L, L-k, L-m$ and sequence $\dots, a_{i+2}, a_{i+1}, a_i, \dots$.

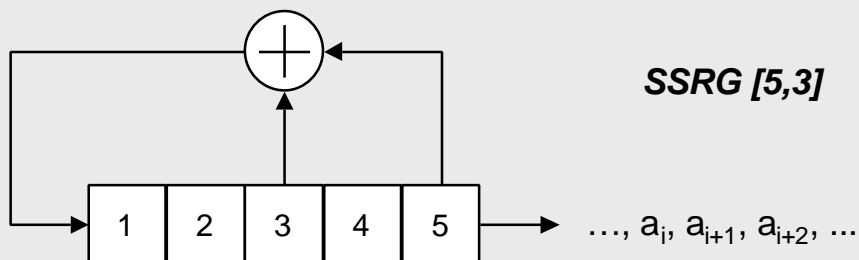

↓ *image*

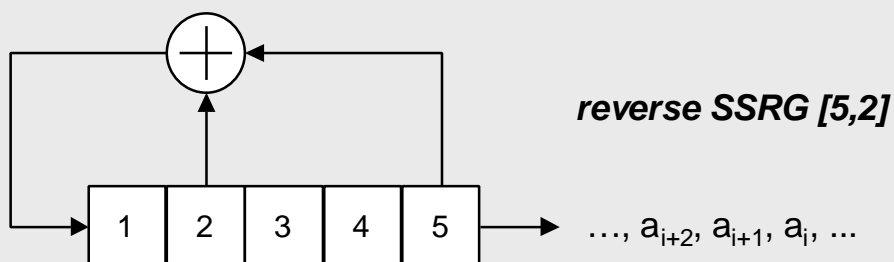

[5,2] = -1 -1 -1 -1 1 -1 1 -1 1 1 -1 1 1 -1 -1 1 1 1 1 1 -1 -1 1 1 -1 1 -1 -1 1

[5,3] = -1 -1 -1 -1 1 -1 -1 1 -1 1 1 -1 -1 1 1 1 1 -1 -1 -1 1 1 -1 1 1 -1 -1 1

In the following table the feedback connections (even number) are tabulated for m-sequences generated with a linear SSRG (without image set).

L	$N_c=2^L-1$	Feedback Taps for m-sequences	# m-sequences
2	3	[2,1]	2
3	7	[3,1]	2
4	15	[4,1]	2
5	31	[5,3] [5,4,3,2] [5,4,2,1]	6
6	63	[6,1] [6,5,2,1] [6,5,3,2]	6
7	127	[7,1] [7,3] [7,3,2,1] [7,4,3,2] [7,6,4,2] [7,6,3,1] [7,6,5,2] [7,6,5,4,2,1] [7,5,4,3,2,1]	18
8	255	[8,4,3,2] [8,6,5,3] [8,6,5,2] [8,5,3,1] [8,6,5,1] [8,7,6,1] [8,7,6,5,2,1] [8,6,4,3,2,1]	16
9	511	[9,4] [9,6,4,3] [9,8,5,4] [9,8,4,1] [9,5,3,2] [9,8,6,5] [9,8,7,2] [9,6,5,4,2,1] [9,7,6,4,3,1] [9,8,7,6,5,3]	48
10	1023	[10,3] [10,8,3,2] [10,4,3,1] [10,8,5,1] [10,8,5,4] [10,9,4,1] [10,8,4,3] [10,5,3,2] [10,5,2,1] [10,9,4,2] [10,6,5,3,2,1] [10,9,8,6,3,2] [10,9,7,6,4,1] [10,7,6,4,2,1] [10,9,8,7,6,5,4,3] [10,8,7,6,5,4,3,1]	60
11	2047	[11,2] [11,8,5,2] [11,7,3,2] [11,5,3,2] [11,10,3,2] [11,6,5,1] [11,5,3,1] [11,9,4,1] [11,8,6,2] [11,9,8,3] [11,10,9,8,3,1]	176

For every set [L, k, ..., p] feedback taps listed in the table, there exists an image set (reverse set) of feedback taps [L, L-k, ..., L-p] that generates an identical sequence reversed in time.

properties

balance

For an m-sequence there is one more “one” than “zero” in a full period of the sequence. Since all states but the ‘all-zero’ state are reached in an m-sequence, there must be 2^{L-1} “ones” and $2^{L-1}-1$ “zeros”.

run-length distribution

For every m-sequence period, half the runs (of all 1's or all 0's) have length 1, one-fourth have length 2, one-eighth have length 3, etc. For each of the runs there are equally many runs of 1's and 0's.

autocorrelation

The autocorrelation function of the m-sequence is -1 for all values of the chip phase shift τ , except for the $[-1, +1]$ chip phase shift area, in which correlation varies linearly from the -1 value to $2^L-1 = N_c$ (the sequence length).

The autocorrelation peak increases with increasing length N_c of the m-sequence and approximates the autocorrelation function of white noise. Other codes can do no better than equal this performance of m-sequences!

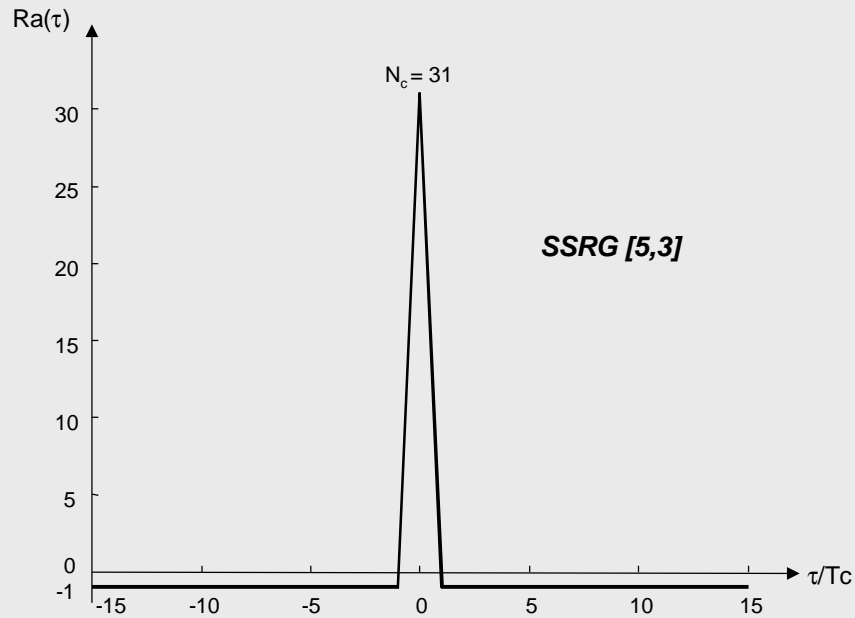

crosscorrelation

Cross-correlation is the measure of agreement between two different codes. Unfortunately, cross-correlation is not so well behaved as autocorrelation. When large numbers of transmitters, using different codes, are to share a common frequency band (multi-user environment), the code sequences must be carefully chosen to avoid interference between users.

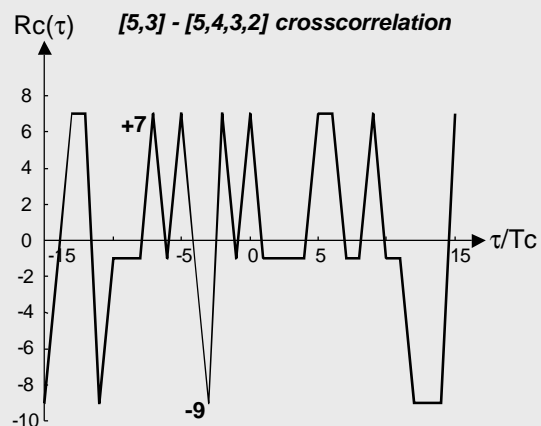
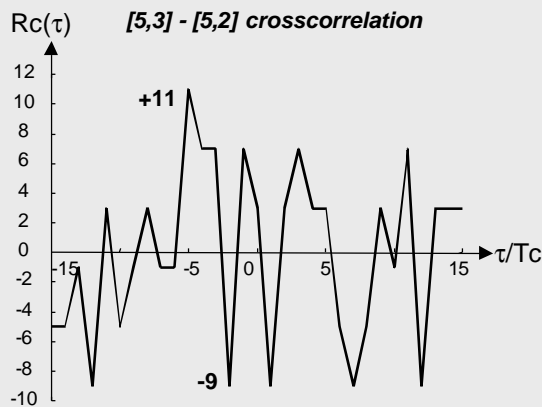

security

The m-sequence codes are linear, and thus not usable to secure a transmission system. The linear codes are easily decipherable once a short sequential set of chips $(2L+1)$ from the sequence is known. (The overall system could still be secure if the information itself were encoded by a cryptographically secure technique).

5.4.2 Barker Code

The number of stages L in the SSRG also determines the length (period) $N_c = 2^L - 1$ of the m-sequence codes. The Barker code gives codes with different lengths and similar autocorrelation properties as the m-sequences.

$$\text{Barker (11)} = 1 -1 1 1 -1 1 1 1 -1 -1 -1 \quad \rightarrow \quad \Sigma = +1 \quad (\text{balanced})$$

$$\text{Barker (13)} = 1 1 1 1 1 -1 -1 1 1 -1 1 -1 1 \quad \rightarrow \quad \Sigma = +5 \quad (\text{unbalanced})$$

The autocorrelation function of the balanced 11 chip Barker code is shown in the next figure.

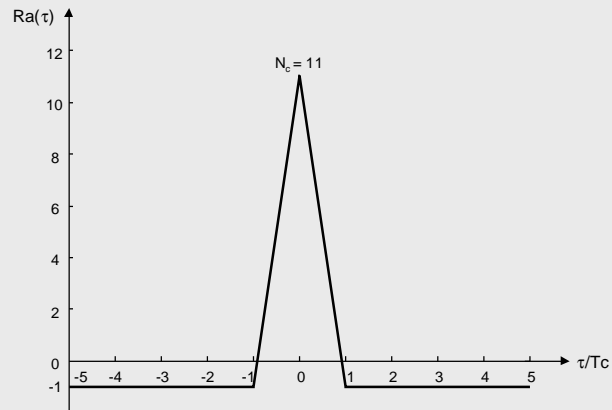

5.4.3 Gold Codes

The autocorrelation properties of the m-sequences cannot be bettered. But a multi-user environment (Code Division Multiple Access) needs a set of codes with the same length and with good cross-correlation properties.

Gold code sequences are useful because a large number of codes (with the same length and with controlled crosscorrelation) can be generated, although they require only one 'pair' of feedback tap sets.

Gold codes are product codes achieved by the exclusive or-ing (modulo-2 adding) of two maximum-length sequences with the same length (factor codes). The code sequences are added chip by chip by synchronous clocking. Because the m-sequences are of the same length, the two code generators maintain the same phase relationship, and the codes generated are of the same length as the two base codes which are added together, but are nonmaximal (so the autocorrelation function will be worse than that of m-sequences). Every change in phase position between the two generated m-sequences causes a new sequence to be generated.

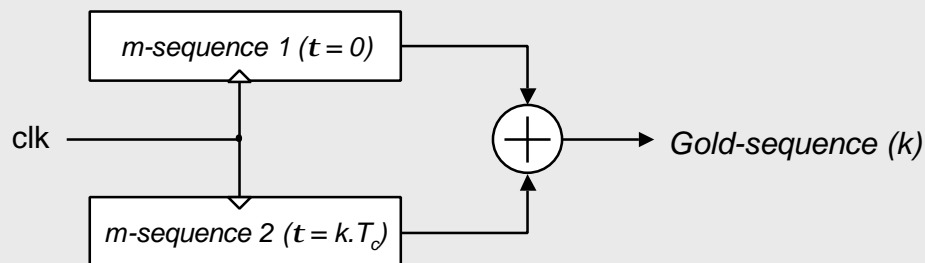

Any 2-register Gold code generator of length L can generate $2^L - 1$ sequences (length $2^L - 1$) plus the two base m-sequences, giving a total of $2^L + 1$ sequences.

In addition to their advantage in generating large numbers of codes, the Gold codes may be chosen so that over a set of codes available from a given generator the autocorrelation and the crosscorrelation between the codes is uniform and bounded. When specially selected m-sequences, called *preferred m-sequences*, are used the generated Gold codes have a three valued crosscorrelation.

L	N_c	normalized 3-value crosscorrelation	Frequency of occurrence
Odd	$2^L - 1$	$-1/N_c$ $-(2^{(L+1)/2} + 1)/N_c$ $(2^{(L+1)/2} - 1)/N_c$	~ 0.50 ~ 0.25 ~ 0.25
Even (not k.4)	$2^L - 1$	$-1/N_c$ $-(2^{(L+2)/2} + 1)/N_c$ $(2^{(L+2)/2} - 1)/N_c$	~ 0.75 ~ 0.125 ~ 0.125

This important subset of Gold codes are the Preferred Pair Gold codes.

L	$N_c=2^L-1$	preferred pairs of m-sequences	3-value crosscorrelations			bound
5	31	[5,3] [5,4,3,2]	7	-1	-9	-29%
6	63	[6,1] [6,5,2,1]	15	-1	-17	-27%
7	127	[7,3] [7,3,2,1] [7,3,2,1] [7,5,4,3,2,1]	15	-1	-17	-13%
8*	255	[8,7,6,5,2,1] [8,7,6,1]	31	-1	-17	+12%
9	511	[9,4] [9,6,4,3] [9,6,4,3] [9,8,4,1]	31	-1	-33	-6%
10	1023	[10,9,8,7,6,5,4,3] [10,9,7,6,4,1] [10,8,7,6,5,4,3,1] [10,9,7,6,4,1] [10,8,5,1] [10,7,6,4,2,1]	63	-1	-65	-6%
11	2047	[11,2] [11,8,5,2] [11,8,5,2] [11,10,3,2]	63	-1	-65	-3%

Predictable cross-correlation properties are necessary in an environment where one code must be picked from several codes which exist in the spectrum.

Only part of the generated Gold codes are balanced.

$$[5,4,3,2] = -1 -1 -1 -1 1 -1 1 1 -1 1 -1 1 -1 -1 1 1 1 -1 1 1 1 1 -1 -1 1 -1 -1 1 1$$

$$[5,3] (0) = -1 -1 -1 -1 1 -1 -1 1 -1 1 1 -1 -1 1 1 1 1 -1 -1 -1 1 1 -1 1 1 1 -1 1 -1 1$$

$$\text{Gold}(0) = -1 -1 -1 -1 -1 -1 1 -1 -1 -1 1 1 -1 1 1 -1 -1 -1 1 1 1 -1 -1 1 1 1 -1 -1 1 1 -1$$

$S \text{ Gold}(0) = -7 = \text{not balanced}$

$$[5,4,3,2] = -1 -1 -1 -1 1 -1 1 1 -1 1 -1 1 -1 -1 1 1 1 -1 1 1 1 1 -1 -1 1 -1 -1 1 1$$

$$[5,3] (1) = 1 -1 -1 -1 -1 1 -1 -1 1 -1 1 1 -1 -1 1 1 1 1 -1 -1 -1 1 1 -1 1 1 1 -1 1 -1$$

$$\text{Gold}(1) = 1 -1 -1 -1 1 1 1 1 1 1 1 -1 -1 -1 1 -1 -1 -1 1 1 1 1 -1 -1 -1 1 -1 1 -1 -1 1$$

$S \text{ Gold}(1) = 1 = \text{balanced}$

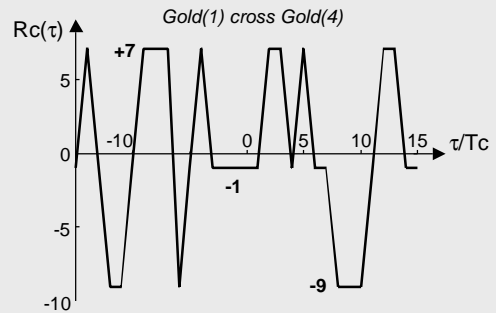
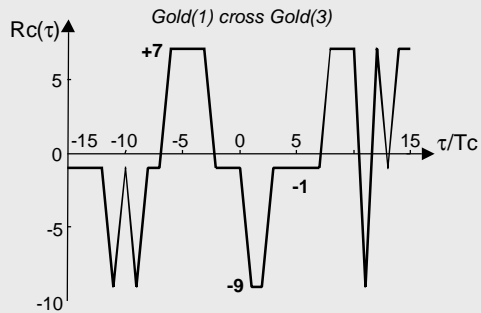
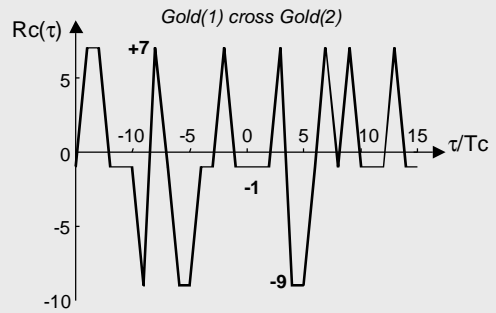
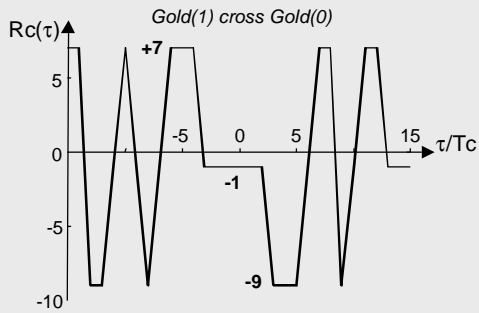
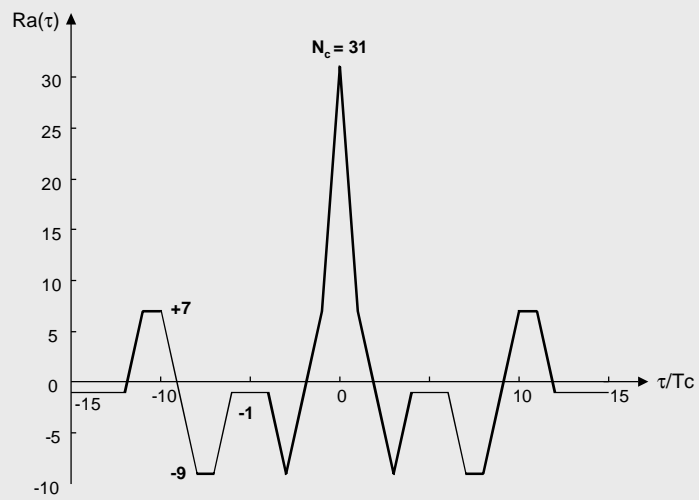
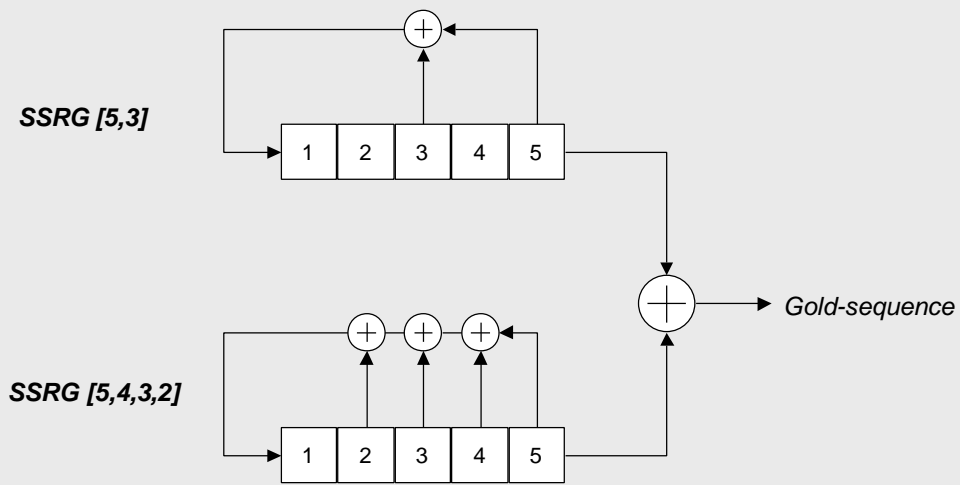

5.4.4 Hadamard-Walsh Codes

The Hadamard-Walsh codes are generated in a set of $N = 2^n$ codes with length $N = 2^n$. The generating algorithm is simple:

$$H_N = \begin{bmatrix} H_{N/2} & H_{N/2} \\ H_{N/2} & -H_{N/2} \end{bmatrix} \quad \text{with} \quad H_0 = [1]$$

The rows (or columns) of the matrix H_N are the Hadamard-Walsh codes.

$$H_2 = \begin{bmatrix} 1 & 1 \\ 1 & -1 \end{bmatrix} \quad H_4 = \begin{bmatrix} 1 & 1 & 1 & 1 \\ 1 & -1 & 1 & -1 \\ 1 & 1 & -1 & -1 \\ 1 & -1 & -1 & 1 \end{bmatrix} \quad H_8 = \begin{bmatrix} 1 & 1 & 1 & 1 & 1 & 1 & 1 & 1 \\ 1 & -1 & 1 & -1 & 1 & -1 & 1 & -1 \\ 1 & 1 & -1 & -1 & 1 & 1 & -1 & -1 \\ 1 & -1 & -1 & 1 & 1 & -1 & -1 & 1 \\ 1 & 1 & 1 & 1 & -1 & -1 & -1 & -1 \\ 1 & -1 & 1 & -1 & -1 & 1 & -1 & 1 \\ 1 & 1 & -1 & -1 & -1 & -1 & 1 & 1 \\ 1 & -1 & -1 & 1 & -1 & 1 & 1 & -1 \end{bmatrix}$$

In each case the first row (row 0) of the matrix consist entirely of 1s and each of the other rows contains $N/2$ 0s and $N/2$ 1s. Row $N/2$ starts with $N/2$ 1s and ends with $N/2$ 0s.

The distance (number of different elements) between any pair of rows is exactly $N/2$. For H_8 the distance between any two rows is 4, so the Hamming distance of the Hadamard code is 4. The Hadamard-Walsh code can be used as a block code in a channel encoder: each sequence of n bits identifies one row of the matrix (there are $N = 2^n$ possible rows).

All rows are mutually orthogonal:

$$\sum_{k=0}^{N-1} h_{ik} \cdot h_{jk} = 0$$

for all rows i and j . The cross-correlation between any two Hadamard-Walsh codes of the same matrix is zero, when perfectly synchronized. In a synchronous CDMA system this ensures that there is no interference among signals transmitted by the same station.

Only when synchronized, these codes have good orthogonal properties. The codes are periodic, which results in less spreading efficiency and problems with synchronization based on autocorrelation.

6. Transmitter Architecture

A typical architecture of a Direct Sequence Spread Spectrum (DS-SS) transmitter:

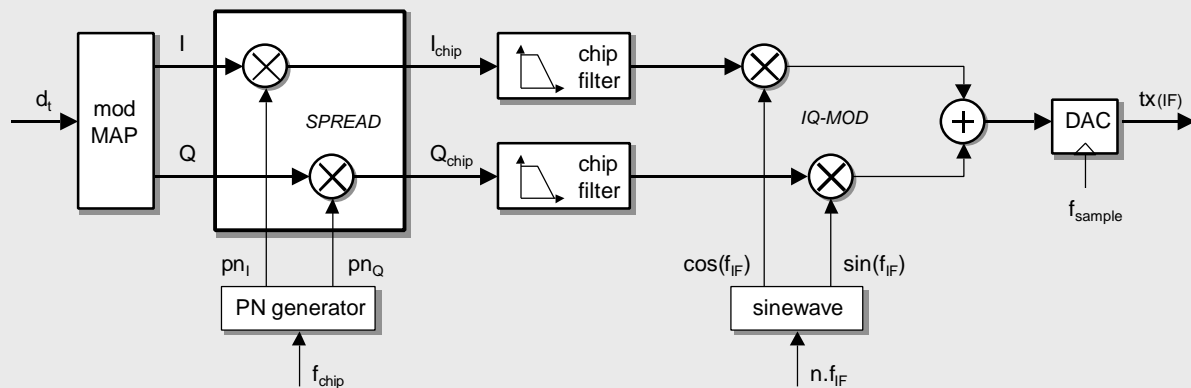

7. Receiver Architecture

A typical architecture of a Direct Sequence Spread Spectrum (DS-SS) receiver:

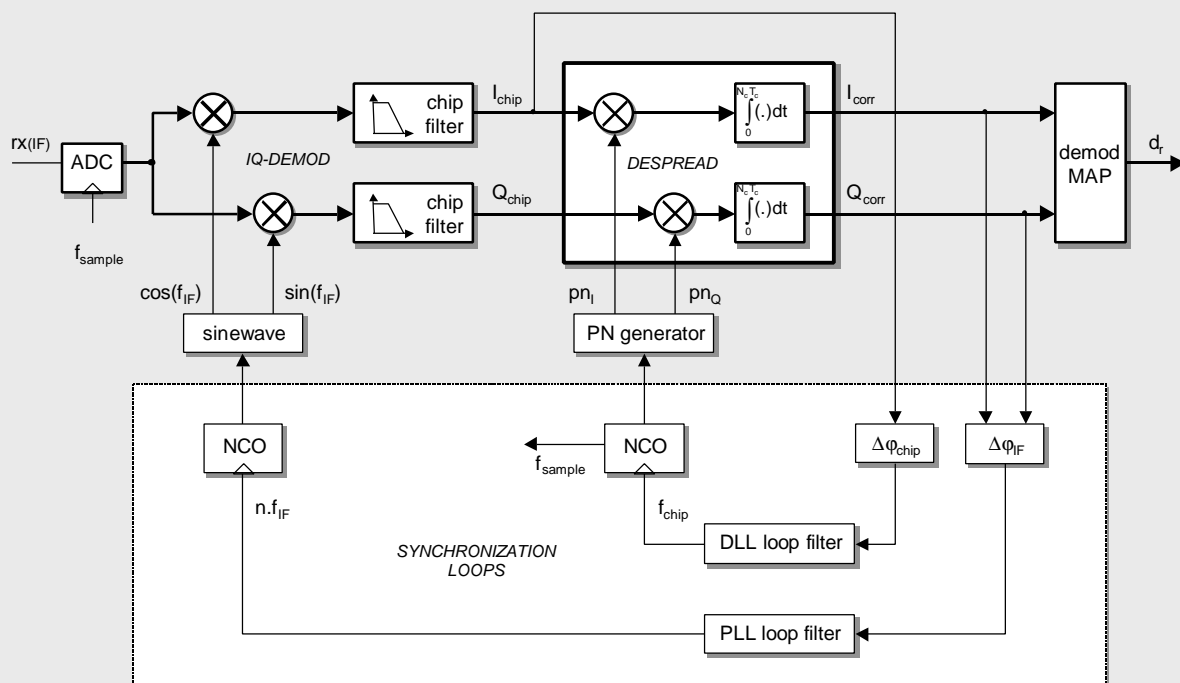

The basic building blocks of a DS-SS (digital) receiver are:

- coherent IQ vector-demodulator with waveform synthesizer (Direct Digital Synthesis) at the IF-carrier frequency (f_{IF}) and chip matched filters (usually Square Root Raised Cosine)
- despreading (correlation of the received symbols with the locally generated PN-sequence(s) pn_I and pn_Q)
- decorrelated 'IQ to data' demodulator mapping
- synchronization loops for the IF-carrier (f_{IF} , phase error $\Delta\phi_{IF}$ measured after despreading to reduce the influence of noise) and chip frequency (f_{chip})

8. PN Decorrelators

Two PN decorrelator architectures can be used for despreading spread spectrum signals: the matched filter and the active correlator. They are optimum from a SNR point of view.

8.1 *PN Matched Filter*

A typical matched filter implements convolution using a finite impulse response filter (FIR) whose coefficients are the time reverse of the expected PN sequence, to decode the transmitted data.

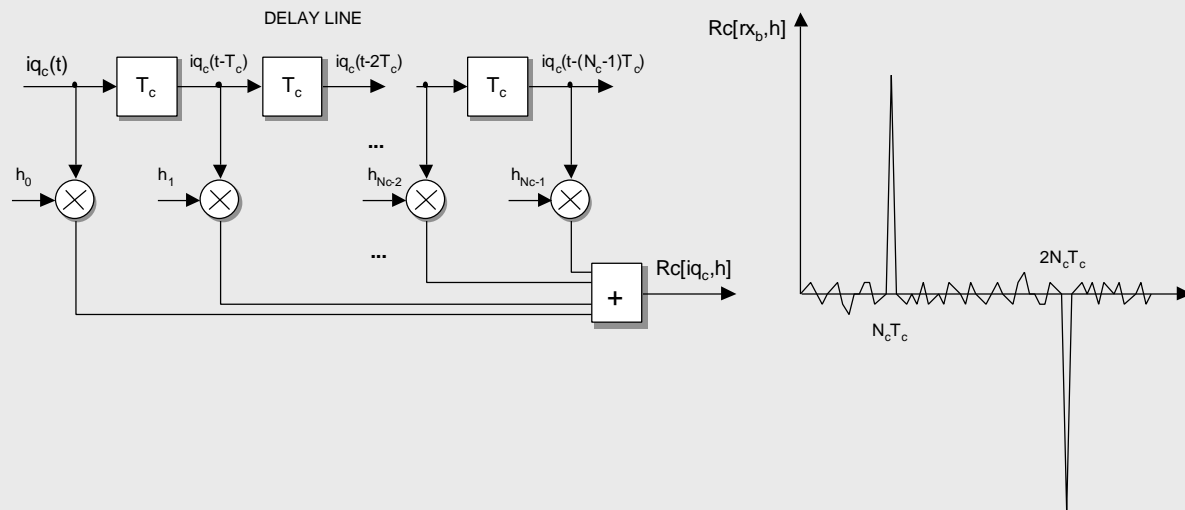

For the given example:

$$p_{n_i} = [p_{n_0} \ p_{n_1} \ p_{n_2} \ p_{n_3} \ p_{n_4} \ p_{n_5} \ p_{n_6}] = [+1 \ +1 \ +1 \ -1 \ +1 \ -1 \ -1]$$

$$h = [h_0 \ h_1 \ h_2 \ h_3 \ h_4 \ h_5 \ h_6] = [-1 \ -1 \ +1 \ -1 \ +1 \ +1 \ +1]$$

The output of the FIR filter is the convolution of the received IQ-demodulated and filtered signal i_{q_c} (I_{chip} or Q_{chip} on the receiver architecture block diagram) with the FIR impulse response $h = [h_0 \ h_1 \ \dots \ h_{N_c-1}]$. Due to the time reversion, the output of the filter is the correlation of r_{x_b} with the local PN sequence.

$$Rc(\tau) = \sum_{i=0}^{N_c-1} i_{q_c}(t - i.T_c).h_i = \sum_{i=0}^{N_c-1} i_{q_c}(t - i.T_c).p_{N_c-1-i}$$

In the shown example, 1 sample of the received signal per chip is taken ($f_{\text{sample}} = f_{\text{chip}}$). To increase the accuracy of synchronization oversampling with a factor s can be used. In this case there are s samples per chip ($f_{\text{sample}} = s.f_{\text{chip}}$). The dimensions of the matched filter are also increased with a factor s (each filter coefficient h_i is used s times).

If the receiver is not synchronized, then the received signal will propagate through the matched filter, which outputs the complete correlation function. The large peak confirms that the correct code is indeed being received and provides accurate timing information for the synchronization of the received signal. The output Rc of the FIR PN matched filter is immediately the decorrelated data: the polarity of the large correlation peaks indicates the data value.

8.2 PN Active Correlator (Integrate and Dump)

When timing information is already available, then the simpler active correlator receiver can be used. This receiver only operates correctly when the local PN sequence pn_r is accurately matched and correctly timed, with respect to the spreading code within the received signal rx_b . Synchronization can be obtained by sliding the reference signal through the received signal. This can be an extremely slow process, however, for large spreading waveforms (long codes).

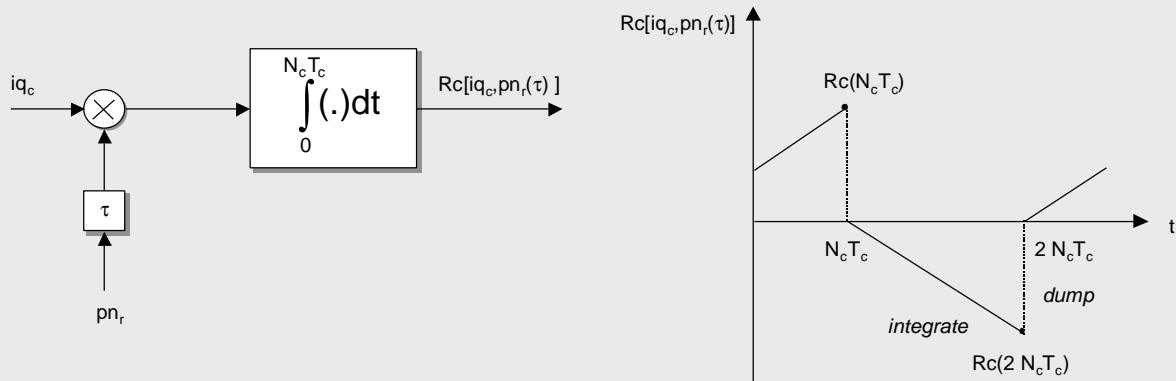

9. PN Synchronization

For its proper operation, a SS communication system requires that the locally generated PN sequence (pn_r used in the receiver Rx to despread the received signal) is synchronized to the PN sequence of the transmitter generator (pn_t used to spread the transmitted signal in the transmitter Tx) in both its rate and its position. Due to the sharp peak in the autocorrelation function, a misalignment in the PN sequence of $T_c/2$ gives a loss of a factor 2 in processing gain.

Sources of Synchronization Uncertainty

Time uncertainty:

- Uncertainty in distance between Tx-Rx (propagation delay)
- Relative clock shifts
- Different phase between Tx-Rx (carrier, PN sequence)

Frequency uncertainty:

- Relative velocity v_r between Tx-Rx (Doppler frequency shift) affects the carrier frequency f_{carrier} (with c the speed of light in the propagation medium):

$$f_{\text{carrier}}^{\text{doppler}} = f_{\text{carrier}} \left(1 \pm \frac{v_r}{c}\right)$$

For a carrier frequency of 2.4 GHz this gives a frequency shift $\Delta f_{\text{carrier}} = 2.2\text{Hz/km/hr}$.
For a relative velocity $v_r = 100 \text{ km/hr}$ this gives $\Delta f_{\text{carrier}} = 220\text{Hz}$.

The process of synchronizing the locally generated PN sequence with the received PN sequence is usually accomplished in two steps. The first step, called *acquisition*, consists of bringing the

two spreading signals into *coarse* alignment with one another. Once the received PN sequence has been acquired, the second step, called *tracking*, takes over and continuously maintains the best possible waveform *fine* alignment by means of a feedback loop. This is essential to achieve the highest correlation power and thus highest processing gain (SNR) at the receiver.

9.1 Acquisition Phase (Coarse Synchronization)

The acquisition problem is one of searching throughout a region of *time* and *frequency* (chip, carrier) in order to synchronize the received spread-spectrum signal with the locally generated PN sequence. Since the despreading process typically takes place before carrier synchronization, and therefore the carrier is unknown at this point, most acquisition schemes utilize noncoherent detection.

A common feature of all acquisition methods is that the received signal and the locally generated PN sequence are first *correlated* with a coarse time step (mostly $T_c/2$) to produce a measure of similarity between the two. This measure is then compared to a threshold to decide if the two signals are in synchronism. If they are, a verification algorithm is started. To prevent false locking, it is necessary to dwell for some time to test synchronism. Then the tracking loop takes over. For proper synchronization, a peaked autocorrelation is required from the PN sequence.

Matched Filter (parallel)

A matched filter calculates the correlation function at each sample timestep T_{sample} . This gives the shortest acquisition time but the fully parallel implementation requires a lot of hardware. The hardware increases with the PN codeword length and the oversampling factor s . Therefore it is mostly used for short codes.

Active Correlator (serial)

An active correlator needs an integration over a total period $N_c \cdot T_c$ of the PN sequence to calculate one point of the correlation function. Less hardware is needed, but a larger acquisition time is required. This can be reduced by using parallelism as explained below.

9.1.1 Serial Synchronization (Sliding Correlator)

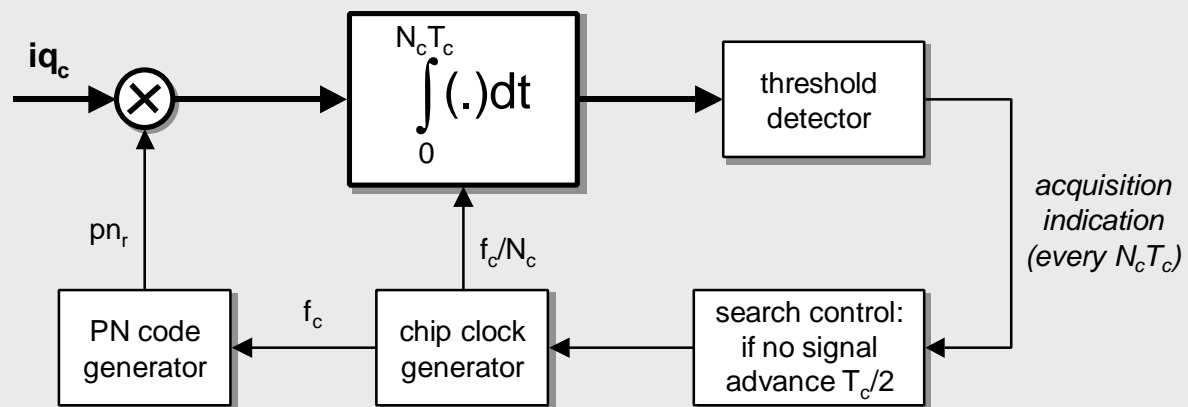

The sliding correlator is based on the correlation result of one active correlator. The correlator cycles through the time uncertainty, usually in discrete time intervals of $T_c/2$ seconds or less. The correlation is performed over the period of the PN sequence $T_s = N_c \cdot T_c$. After each integration interval the correlator output is compared with a threshold to determine if the known PN sequence is present. If the threshold is not exceeded, the known PN sequence of the receiver (pn_r) is advanced by $T_c/2$ seconds and the correlation process is repeated. These operations are performed until a signal is detected or until the search has been performed over the time

uncertainty interval T_u . For a coarse time step of $T_c/2$ the worst case acquisition time is ($T_u = N_c T_c$):

$$T_{\text{acq}} = [T_u / T_c/2] \cdot N_c T_c = 2 N_c T_u = 2 N_c^2 T_c$$

This becomes unacceptable long for long codes (large N_c).

9.1.2 Serial/Parallel Synchronization

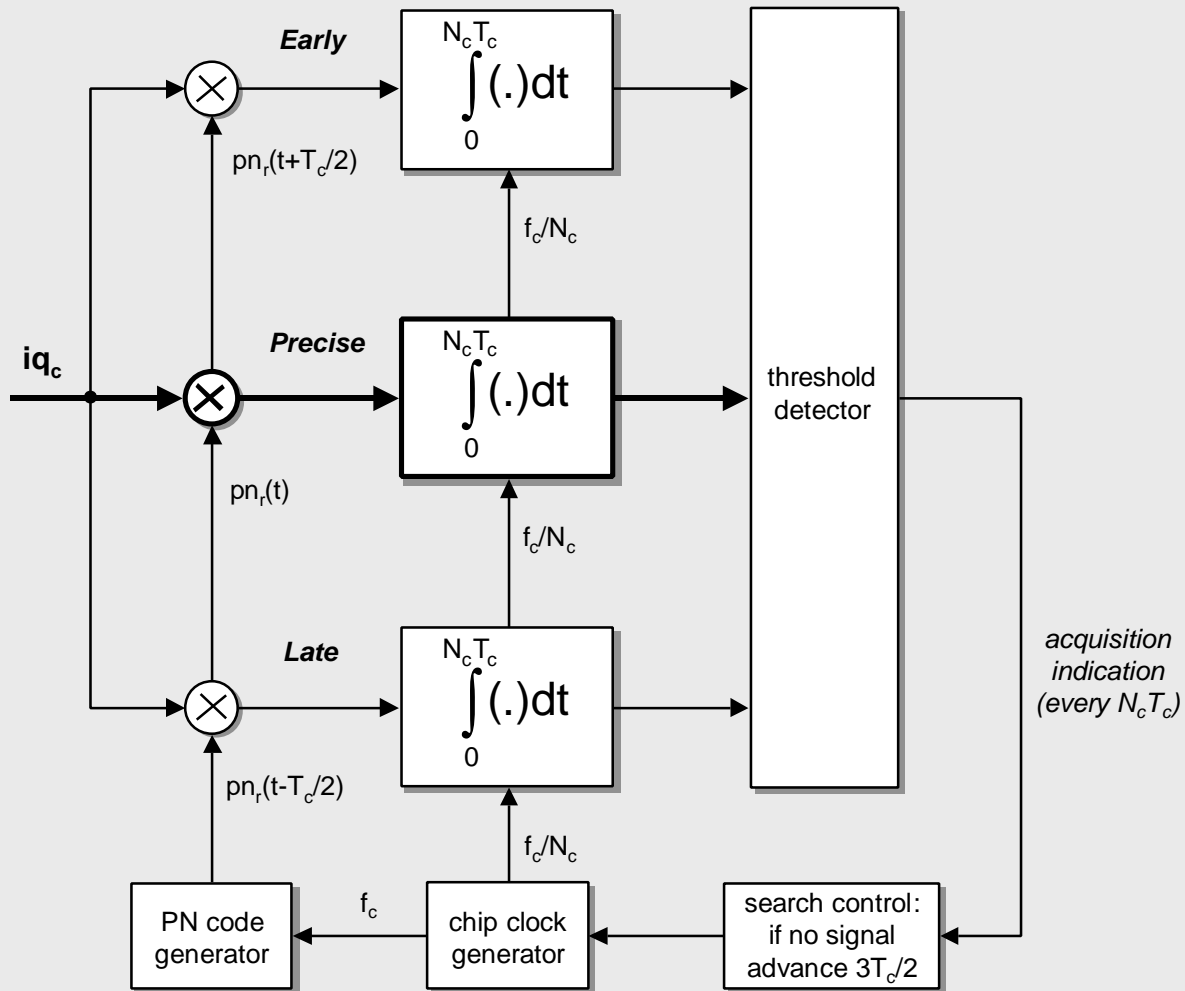

More active correlators are placed in parallel (3 in this example) with PN sequences spaced one half chip ($T_c/2$) apart. After the integration period $N_c T_c$ the results of the correlator outputs are compared. The correlation function is thus calculated in 3 successive points (spaced one half chip apart). When no comparator output exceeds the threshold the sequences are advanced over $3T_c/2$ seconds. When the threshold is exceeded, the correlator output with the largest output is chosen. For a search with 3 parallel correlators over the time uncertainty T_u interval in time steps of $T_c/2$ the worst case acquisition time is ($T_u = N_c T_c$):

$$T_{\text{acq}} = [T_u / 3T_c/2] \cdot N_c T_c = 2/3 N_c T_u = 2/3 N_c^2 T_c$$

The search time is reduced at the expense of a more complex and costly implementation.

9.2 Tracking Phase (Fine Synchronization)

The tracking maintains the PN code generator at the receiver in synchronism with the received signal. This is needed to achieve maximum processing gain. For a PN sequence phase error of $T_c/2$ the processing gain is reduced with a factor 2.

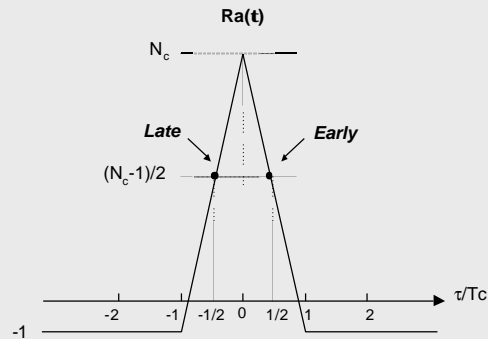

Delay-Locked Loop (DLL)

The locally generated code $pn_r(t)$ of the tracking loop is offset in phase from the incoming $pn(t)$ by a time τ , with $\tau < T_c/2$. In the DLL, two PN sequences $pn_r(t + T_c/2 + \tau)$ and $pn_r(t - T_c/2 + \tau)$ are delayed from each other by one time chip (T_c). The Early and Late outputs are the evaluation of the autocorrelation function at two timepoints: $c_e = Ra(\tau - T_c/2)$ $c_l = Ra(\tau + T_c/2)$.

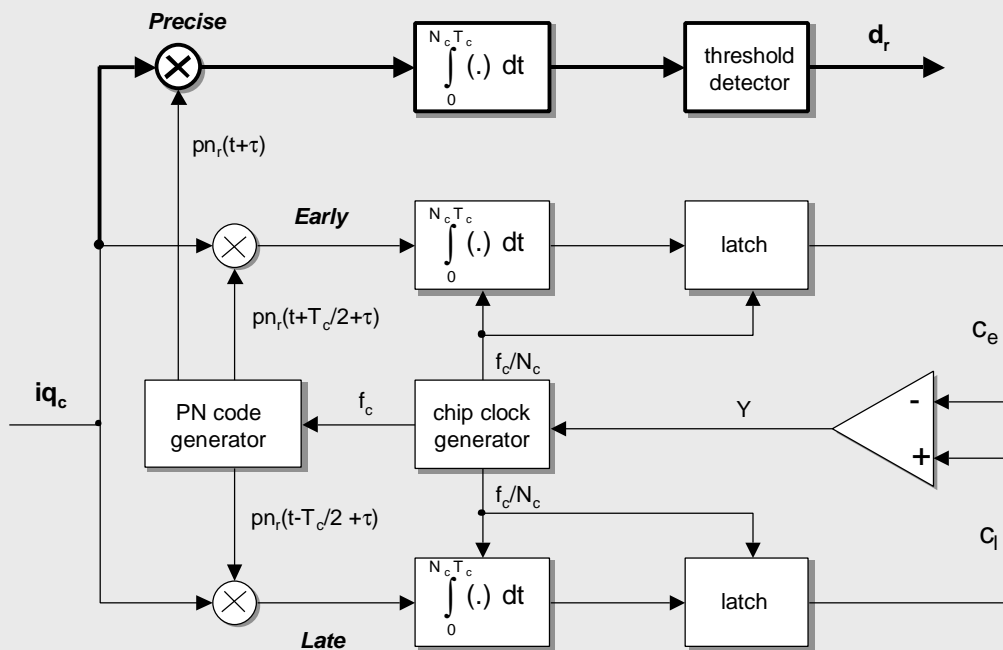

When τ is positive, the feedback signal $Y(t)$ instructs the chip clock generator (NCO = numerical controlled oscillator) to increase its frequency, thereby forcing τ to decrease. When τ is negative, the feedback signal $Y(t)$ instructs the numerical controlled oscillator (NCO) to decrease its frequency, thereby forcing τ to increase.

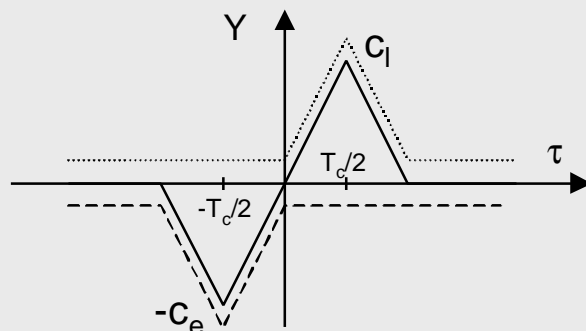

10. Multiple Access

Code Division Multiple Access (CDMA) is a method of multiplexing (wireless) users by distinct (orthogonal) codes. All users can transmit at the same time, and each is allocated the entire available frequency spectrum for transmission. CDMA is also known as spread-spectrum multiple access SSMA.

CDMA does not require the bandwidth allocation of FDMA, nor the time synchronization of the individual users needed in TDMA. A CDMA user has full time and full bandwidth available, but the quality of the communication decreases with an increasing number of users ($BER \uparrow$).

In CDMA each user:

- has its own PN code
- uses the same RF bandwidth
- transmits simultaneously (asynchronous or synchronous)

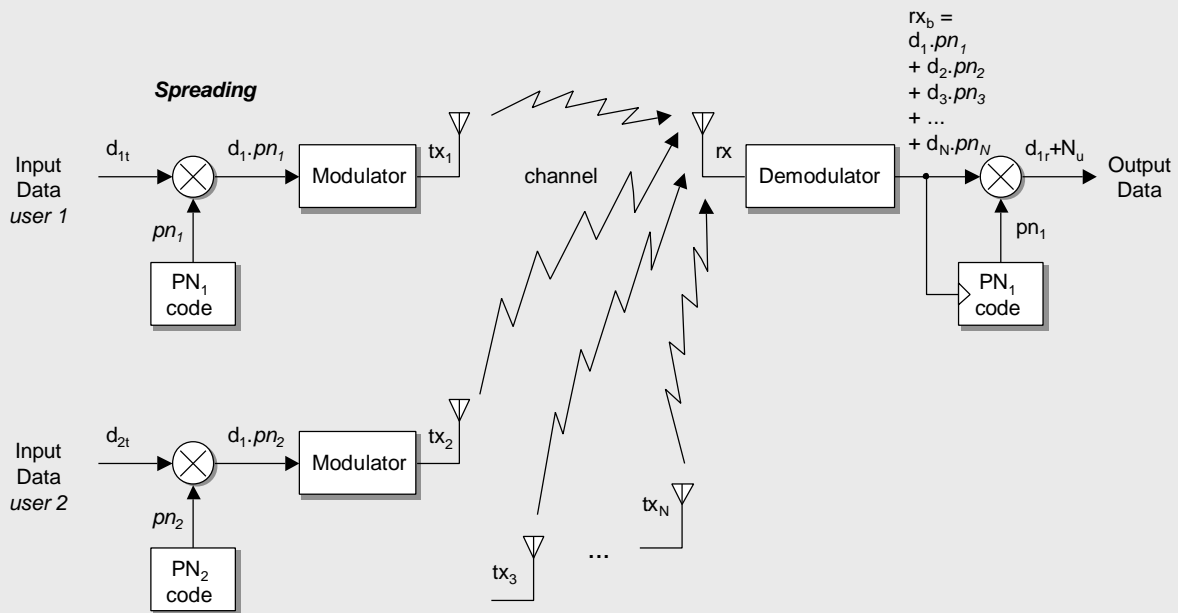

Correlation of the received baseband spread spectrum signal rx_b with the PN sequence of user 1 only despreads the signal of user 1. The other users produce noise N_u for user 1.

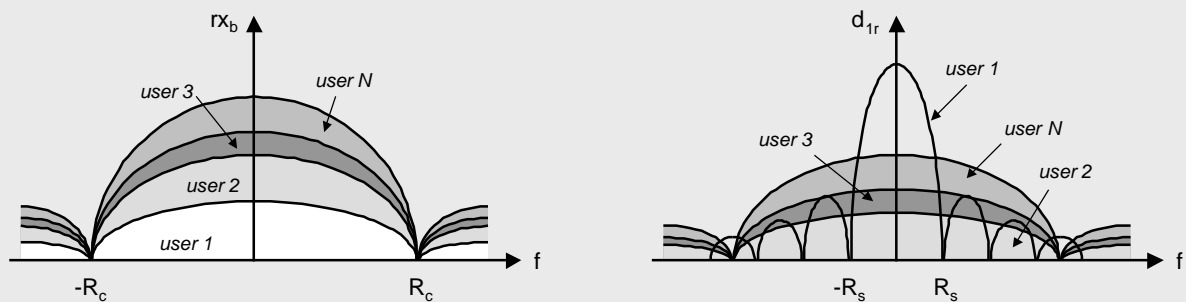

Only that portion of the noise produced by the other users falling in the information bandwidth $[-R_s, R_s]$ of the receiver, will cause interference with the desired signal.

The set of PN codes must have the following properties:

- autocorrelation for good synchronization
- low crosscorrelation (orthogonal codes) for low MAI

Useful codes are:

- Gold codes, Kasami codes (asynchronous CDMA)
- Hadamard-Walsh codes (synchronous CDMA)

Multiple Access Interference (MAI)

The detector receives a signal composed of the sum of all users' signals, which overlap in time and frequency. Multiple access interference (MAI) refers to the interference between direct-sequence users and is a factor which limits the capacity and performance of DS-CDMA systems.

In a conventional DS-CDMA system, a particular user's signal is detected by correlating the entire received signal with that user's code waveform. The conventional detector does not take into account the existence of MAI. Because of the interference among users, however, a better detection strategy is one of multi-user detection. Information about multiple users is used jointly to better detect each individual user.

Near-Far problem

Suppose:

- Wireless channel
- Multi-users (transmitters) using the same channel
- One receiver

Each user is a source of interference for the other users, and if one is received with more power, than that user generates more interference for the other users. It is important that the receiver gets the same power from each transmitter. The use of *power control* ensures that all users arrive at about the same power P_{rx} at the receiver, and therefore no user is unfairly disadvantaged relative to the others. The signal-to-noise interference power ratio at the receiver input for N_u simultaneous users is:

$$SNR = \frac{P_{rx}}{(N_u - 1) \cdot P_{rx}} = \frac{1}{(N_u - 1)}$$

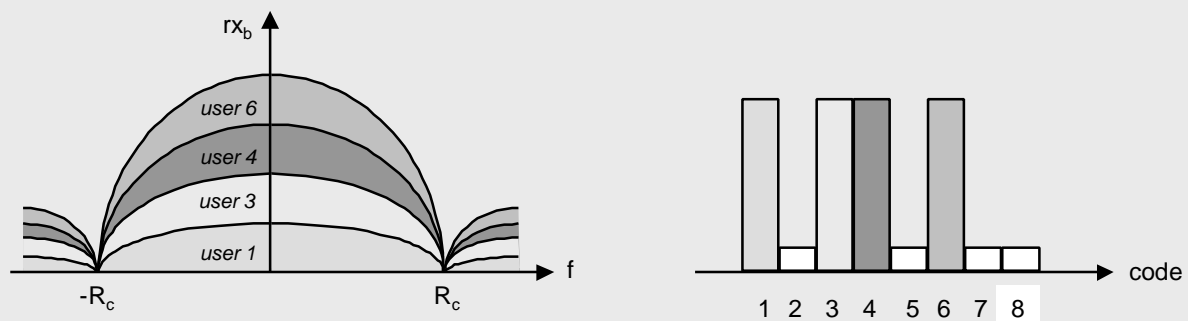

11. Multipath Channels

In wireless channels there exists often multiple path propagation: there is more than one path from the transmitter to the receiver. Such multipaths may be due to:

- Atmospheric reflection or refraction
- Reflections from ground, buildings or other objects

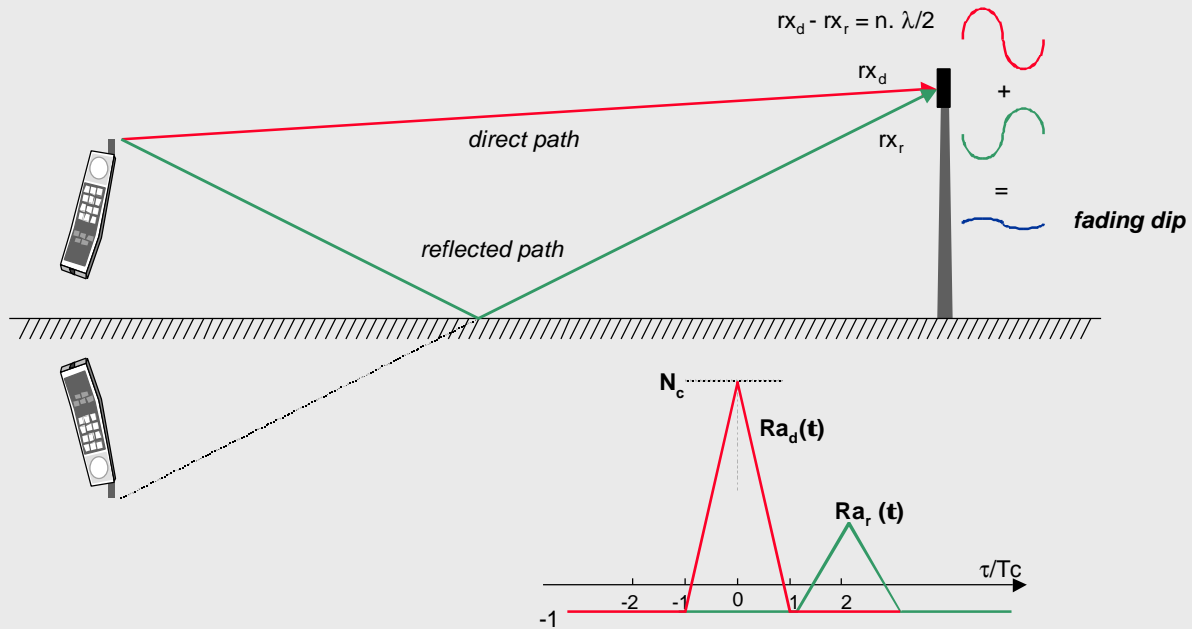

Multipaths may result in fluctuations in the received signal level (fading). Each path has its own attenuation and time delay. It is important to keep the direct path and reject the others. Assume that the receiver is synchronized to the time delay and RF phase of the direct path. The signals at the receiver can be from: the direct path, other paths, white noise, interference.

Suppose two discrete paths: a direct path and only one non-direct path (delayed by a time τ compared to the direct path).

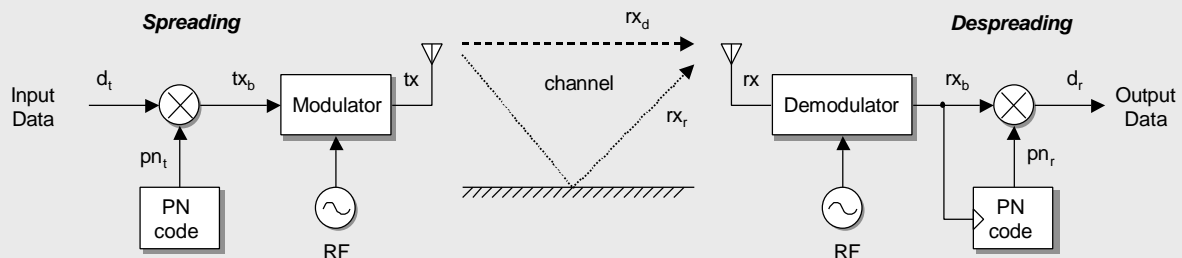

τ = differential time delay between the two paths $0 < \tau < T$

θ = random angle phase between the carrier of the direct and the non-direct path

α = attenuation of the secondary path

The signal at the receiver can be expressed as:

$$r_x = r_{x_d} + r_{x_r} + n = A d_t(t) p_n(t) \cos(\omega_0 t) + \alpha A d_t(t-\tau) p_n(t-\tau) \cos(\omega_0 t + \theta) + n(t)$$

For the receiver, synchronized to the direct path signal, the output of the correlator, can be written as:

$$d_r(t = N_c T_c) = \int_0^{N_c T_c} p_n(t) \cdot r_x(t) dt = \int_0^{N_c T_c} [B \cdot p_n(t) \cdot p_n(t) + C \cdot p_n(t) \cdot p_n(t - \tau) + n(t)] dt$$

The PN sequence has an autocorrelation function with the property:

$$\begin{aligned} p_n(t) p_n(t) &= 1 \\ p_n(t) p_n(t-\tau) &\neq 1 \end{aligned}$$

Multipath signals that are delayed by a chip period or longer relative to the desired signal (outdoor reflections) are essentially uncorrelated and do not contribute to multipath fading. The SS System effectively rejects (mitigation) the multipath interference like in the case of CDMA.

$$d_r(t = N_c T_c) = d_t + n_0$$

with n_0 = noise and multipath interference

The PN code that arrives from the non-direct channel(s) is not synchronized to the PN code of the direct path and is rejected.

12. Jamming

The goal of a jammer is to disturb the communication of his adversary. The goals of the communicator are to develop a jam-resistant communication system under the following assumptions:

- Complete invulnerability is not possible
- The jammer has a priori knowledge of most system parameters, frequency bands, timing, traffic, ...
- The jammer has no a priori knowledge of the PN spreading code

Protection against jamming waveforms is provided by purposely making the information-bearing signal occupy a bandwidth far in excess of the minimum bandwidth necessary to transmit it. This has the effect of making the transmitted signal assume a noise-like appearance so as to blend into background.

The transmitted signal is thus enabled to propagate through the channel undetected by anyone who may be listening. Spread spectrum is a method of "camouflaging" the information-bearing signal.

13. ISM Bands

ISM (Industrial, Scientific, and Medical) frequency bands are reserved for (unlicensed) spread spectrum applications.

ISM-Band	Bandwith
902-928 MHz	26 MHz
2.4 - 2.4835 GHz	83.5 MHz
5.725 - 5.850 GHz	125 MHz

Properties for higher frequencies:

- higher path loss, shorter distance
- higher implementation cost
- + less interference
- + more channels, higher throughput

Regulations for the 2.4 GHz ISM band:

Maximum Transmit Power	Geographic Location	Compliance Document
1000 mW [4 W EIRP]	USA	FCC 15.247
100 mW EIRP (P _t G _t)	Europe	ETS 300 328
10mW/MHz	Japan	MPT ordinance 79

USA → FCC (Federal Communications Commission)

Europe ® ETS (European Telecommunication Standard):

	Peak Power Density (ETS 300 328)
FHSS	100 mW / 100 kHz EIRP
DSSS	10 mW / 1 MHz EIRP

FHSS = Frequency Hopping Spread Spectrum

- ≥ 20 non-overlapping channels (hopping positions)
- dwell time/channel ≤ 400 ms
- each channel occupied at least once during $\leq 4 \cdot (\#channels) \cdot (\text{dwell time/hop})$

DSSS = Direct Sequence Spread Spectrum

Spread spectrum modulation that does not satisfy the constraints of the FHSS specification.

14. Evaluation of SS

Positive

1. Signal hiding (lower power density, noise-like), non-interference with conventional systems and other SS systems
2. Secure communication (privacy)
3. Code Division Multiple Access CDMA (multi-user)
4. Mitigation (rejection) of multipath, hold only the direct path
5. Protection to intentional interference (Jamming)
6. Rejection of unintentional interference (narrowband)
7. Low probability of detection and interception (LPI)
8. Availability of licence-free ISM (Industrial, Scientific and Medical) frequency-bands

Negative

9. No improve in performance in the presence of Gaussian noise
10. Increased bandwidth (frequency usage, wideband receiver)
11. Increased complexity and computational load

15. References

1. Sklar B., 'A structured Overview of Digital communications - A Tutorial Review - Part I', IEEE Communications Magazine, August 1983
2. Sklar B., 'A structured Overview of Digital communications - A Tutorial Review - Part II', IEEE Communications Magazine, October 1983
3. B. Sklar, 'Digital Communications', Prentice-Hall , 1988 , chap 10
4. J.G. Proakis, 'Communication Systems Engineering', Prentice-Hall, 1994, chap 11
5. Glover and Grant , 'Digital Communications', Prentice Hall, 1997, chap 15
6. Viterbi, 'CDMA Principles of Spread Spectrum Communication', Addison-Wesley, 1995
7. Raymond L. Pickholtz, Donald L. Schilling and Laurence B. Milstein, 'Theory of spread-spectrum communications- A Tutorial', IEEE Trans. on Communications, vol. com-30, no. 5, May 1982, pp. 855-884
8. R.C. Dixon, 'Spread Spectrum Systems with commercial applications', John Wiley & Sons, Inc., 1994
9. J.K. Holmes, Coherent Spread Spectrum Systems, John Wiley & Sons, 1982
10. M.K. Simon, 'Spread Spectrum Communications Handbook', Mc Graw-Hill, Inc., 1994
11. Shimon Moshavi, Bellcore, 'Multi-user Detection for DS-CDMA Communications', IEEE communications magazine, October 1996, pp. 124-136
12. E. Dinan and B. Jabbari, "Spreading Codes for Direct Sequence CDMA and Wideband CDMA cellular Networks", IEEE communications magazine, October 1996, pp. 124-136